

SAFEPATH4 AUDIO BOOSTER

SPB-80/4 P/N 108988

SPB-160 P/N 108989

Installation, Testing, Operation, and Maintenance Manual



273 Branchport Avenue, Long Branch, NJ 07740-6899 Ph: (800) 631-2148 Fax: (732) 222-2588
Toll Free 800-631-2148 Web Site: www.wheelockinc.com E-Mail: info@wheelockinc.com

Part Number P84296 Revision H

Assembly Number A84347 Revision A

Intentionally Blank

Typographical Notation Conventions

Thank you for using our products. Use this product according to this instruction manual. Please keep this instruction manual for future reference.

ANY MATERIAL EXTRAPOLATED FROM THIS DOCUMENT OR FROM WHEELLOCK MANUALS OR OTHER DOCUMENTS DESCRIBING THE PRODUCT FOR USE IN PROMOTIONAL OR ADVERTISING CLAIMS, OR FOR ANY OTHER USE, INCLUDING DESCRIPTION OF THE PRODUCT'S APPLICATION, OPERATION, INSTALLATION AND TESTING IS USED AT THE SOLE RISK OF THE USER AND WHEELLOCK WILL NOT HAVE ANY LIABILITY FOR SUCH USE.

Certain information contained in this manual has been extracted from the NFPA 72 Manual (1999 Edition) and the Life Safety Code 101™ Manual (2000 Edition).

Notation Conventions

This manual uses the following notation conventions:

 WARNING: INDICATES A POTENTIALLY HAZARDOUS SITUATION THAT, IF NOT AVOIDED, COULD RESULT IN PROPERTY DAMAGE AND SERIOUS PERSONAL INJURY OR DEATH TO YOU AND OR OTHERS.

 CAUTION: Indicates a potentially hazardous situation that, if not avoided, could result in minor or moderate injury. It may also be used to alert against unsafe practices.

Intentionally Blank

Table of Contents

Typographical Notation Conventions.....	3
Table of Contents.....	5
List of Figures.....	7
List of Tables.....	8
Chapter 1 – Safety Precautions.....	9
Section 1-1 – Read This Manual.....	9
Section 1-2 – Operational Safety.....	9
Section 1-3 – Compliance with Applicable Codes, Regulations, Laws, Standards, And Guidelines.....	10
Section 1-4 – Property Insurance Recommendation.....	10
Section 1-5 – Audio Output Considerations.....	10
Section 1-6 – RF Interference.....	11
Section 1-7 – General.....	11
Chapter 2 – Overview and Features.....	13
Section 2-1 – Description.....	13
Section 2-2 – Enclosure and Configuration.....	13
Section 2-3 – Nominal Electrical Data.....	13
Section 2-4 – Operation Modes.....	13
Chapter 3 – Installation and Setup.....	19
Section 3-1 – Introduction.....	19
Section 3-2 – Two Wire and Four Wire Audio Modes.....	19
Section 3-3 – General Installation Instructions.....	22
Section 3-4 – Panel Wiring.....	30
Section 3-5 – Mounting.....	34
Section 3-6 – System Checkout.....	35
Section 3-7 – Ground Fault Detection	38
Section 3-8 – Battery Care and Backup Battery Calculations.....	38
Section 3-9 – AC Power and Battery Installation Procedures.....	40
Chapter 4 – Operation.....	42
Section 4-1 – Introduction.....	42
Section 4-2 – Supervision.....	42
Section 4-3 – Actions That Initiate Alarms.....	43
Chapter 5 – Operational Procedures.....	44
Section 5-1 – Operator Instructions.....	44
Chapter 6 – Periodic Testing and Maintenance.....	46
Section 6-1 – Introduction.....	46

Section 6-2 – Periodic Testing.....	46
Section 6-3 – Faulty Equipment.....	46
Section 6-4 – Qualified Personnel.....	46
Section 6-5 – Miscellaneous Hardware Testing.....	47
Chapter 7 – Troubleshooting.....	48
Section 7-1 – Introduction.....	48
Section 7-2 – Troubleshooting.....	48
Section 7-3 – Audio Booster Wiring Diagram.....	56
Chapter 8 – Technical Data.....	57
Section 8-1 – Mechanical.....	57
Section 8-2 – Environmental.....	57
Section 8-3 – Electrical.....	57
Chapter 9 – Module Descriptions.....	59
Section 9-1 – Introduction.....	59
Section 9-2 – Audio Booster Audio Booster PC Board	59
Section 9-3 – 24VDC Power Supply (SAPS).....	60
Chapter 10 – Warranty.....	61
Chapter 11 – Battery Backup Calculation Work Sheet.....	63
Appendix E - Compatible Appliances.....	See Attachment

List of Figures

Figure 2-1	Basic Capabilities of the SPB-80/4 SAFEPATH4 Audio Booster Panel.....	15
Figure 2-2	Basic Capabilities of the SPB-160/4 SAFEPATH4 Audio Booster Panel.....	15
Figure 2-3	Layout of a SPB-80/4 SAFEPATH4 Audio Booster Panel.....	16
Figure 2-4	Layout of a SPB-160 SAFEPATH Audio Booster Panel.....	17
Figure 3-1	Connections for Multiple Audio Booster in Two-Wire Mode (SPB-160).....	20
Figure 3-2	Connections for Multiple Audio Booster in Two-Wire Mode (SPB-80/4).....	21
Figure 3-3A	Location of Field Wire Connections (SPB-160).....	23
Figure 3-3B	Location of Field Wire Connections (SPB-80/4).....	24
Figure 3-4	Removable Terminal Block.....	26
Figure 3-5	Power Limited and Non-Power Limited Wiring.....	26
Figure 3-6	Audio and Auxiliary Connections (SPB-160 and SPB-80/4).....	27
Figure 3-7	Strobe Input Connections (SPB-80/4).....	27
Figure 3-8	Audio and Strobe Output Connections (SPB-80/4).....	28
Figure 3-9	Audio Output Connections (SPB-160).....	28
Figure 3-10	Alarm and Trouble Connections (SPB-160 and SPB-80/4).....	29
Figure 3-11	Power and Battery Connections.....	29
Figure 3-12	Wiring Diagram - Visual Only Notification Appliances (SPB-80/4).....	32
Figure 3-13	Wiring Diagram - Combination Audio/Visual Notification Appliances (SPB-80/4)...	32
Figure 3-14	Wiring Diagram - Audio Only Notification Appliance Output.....	32
Figure 3-15	Trouble Status Relay Contacts.....	33
Figure 3-16	Input Power Connection Location on the SAPS Power Supply.....	33
Figure 3-17	DC and Battery Connection on the Audio Booster PC Board.....	34
Figure 3-18	SAFEPATH4 Audio Booster Panel Mounting and Grounding Location.....	35
Figure 3-19A	Jumper/Switch/Variable Resistor Location on SPB-160.....	36
Figure 3-19B	Jumper/Switch/Variable Resistor Location on SPB-80/4.....	36
Figure 7-1A	SPB-160 LED Locations.....	49
Figure 7-1B	SPB-80/4 LED Locations.....	50
Figure 7-2	Audio Booster Wiring Diagram.....	56
Figure 9-1A	SPB-80/4 PC Board.....	59
Figure 9-1B	SPB-160 PC Board.....	60
Figure 9-2	24VDC Power Supply Module (SAPS).....	60

List of Tables

Table 2-1 Standard Features..... 14

Table 3-1 Terminal Connection Definitions..... 25

Table 3-2 Jumper/Switch/Variable Resistor Functions.....37

Table 6-1 Miscellaneous Hardware Tests..... 47

Table 7-1 Trouble LED Procedure Cross Reference..... 51

Table 8-1 Mechanical.....57

Table 8-2 Environmental.....57

Table 8-3 Electrical.....57

Table 8-4 Outputs..... 58

Table 8-5 Wiring Connections..... 58

Table 8-6 End of Line Resistor (EOLR)..... 58

Chapter 1 - Safety Precautions

Section 1-1 - Read This Manual

Personnel properly qualified in the application and use of life safety equipment ("qualified personnel") shall read this manual carefully before performing any actions to specify, apply, install, maintain and operationally test **SAFEPATH4 Audio Booster** products in accordance with the instructions in this manual.

This manual shall be kept with the **SAFEPATH4 Audio Booster** panel for reference during the life of the system. This manual shall be made available to all qualified personnel who operate, test, maintain, or service **SAFEPATH4 Audio Booster** products. It is strongly recommend that such personnel read and understand the entire manual.

Section 1-2 - Operational Safety

⚠ WARNING: IF SAFETY PRECAUTIONS, INSTALLATION AND TESTING INSTRUCTIONS ARE NOT PERFORMED PROPERLY, THE SAFEPATH4 AUDIO BOOSTER PANEL MAY NOT OPERATE IN AN EMERGENCY SITUATION WHICH COULD RESULT IN PROPERTY DAMAGE AND SERIOUS INJURY OR DEATH TO YOU AND/OR OTHERS.

⚠ WARNING: IF THE PROTECTIVE SIGNALING SYSTEM SOUNDS AND/OR FLASHES, IT IS A WARNING THAT A POSSIBLE SERIOUS SITUATION REQUIRES IMMEDIATE ATTENTION.

⚠ CAUTION: SAFEPATH4 Audio Booster printed circuit boards are sensitive to static electricity and have delicate components mounted on it. Discharge any static electricity from your body by touching a grounded object, such as a metal screw, which is connected to earth ground. Handle the board by its edges and be careful not to twist or flex it. The **SAFEPATH4 Audio Booster** panel is to be installed in a static free area, and the user is to properly attach grounded wrist straps before touching any static sensitive areas. After handling **SAFEPATH4 Audio Booster** printed circuit board, the panel should be tested in accordance with Section 3-6 "System Checkout" of this manual to verify that it is functioning properly.

This **SAFEPATH4 Audio Booster** panel **will not work without power.** The **SAFEPATH4 Audio Booster** panel is powered by 120VAC. 24VDC re-chargeable batteries provide backup power. If both sources of power are cut off for any reason, the **SAFEPATH4 Audio Booster** panel will not operate.

DO NOT assume any installation, operation and testing details not shown in this manual.

Notification equipment cannot last forever. Even though **SAFEPATH4 Audio Booster** is expected to last up to ten years, any of its parts or components could fail before then. Therefore testing of the entire protective signaling system, including the **SAFEPATH4 Audio Booster** panel, all notification equipment, as well as all messages and their output channel, and priority assignment, shall be conducted at least twice each year, or more often as required by local, state and federal codes, regulations and laws, by qualified personnel. If the notification equipment is not working properly, immediately contact the installer and have all/any problems corrected immediately. Malfunctioning components should be replaced immediately. Do not attempt to repair malfunctioning components. Malfunctioning components should be returned for factory repair or replacement. In the event you cannot contact the installer, contact the manufacturer.

⚠ WARNING: FOR PROPER OPERATION IN LIFE SAFETY APPLICATIONS, THE *SAFEPATH4* AUDIO BOOSTER PANEL SHALL BE CONNECTED TO A LISTED COMPATIBLE AND PROPERLY OPERATING VOICE EVACUATION PANEL SUCH AS THE WHEELLOCK, INC SP40/2 PANEL, WHICH CONTROLS ITS ACTIVATION. ALL EQUIPMENT SHALL BE PROPERLY INTERCONNECTED AND OPERATING. THE INSTALLER SHALL CHECK COMPATIBILITY OF ALL EQUIPMENT PRIOR TO INSTALLATION, OTHERWISE THE *SAFEPATH4* AUDIO BOOSTER PANEL AND/OR THE VOICE EVACUATION PANEL MAY BE DAMAGED AND/OR FAIL TO OPERATE IN AN EMERGENCY SITUATION.

⚠ WARNING: CERTAIN HARDWARE FUNCTIONS ON THE *SAFEPATH4* AUDIO BOOSTER PANEL ARE NOT SUPERVISED. IF ANY SUCH HARDWARE FUNCTIONS FAIL, THE *SAFEPATH4* AUDIO BOOSTER PANEL MAY NOT PROVIDE THE INTENDED WARNING AND/OR NOT INDICATE A TROUBLE CONDITION.

Section 1-3 - Compliance with Applicable Codes, Regulations, Laws, Standards, and Guidelines

COMPLY WITH ALL OF THE LATEST APPLICABLE CODES, REGULATIONS, LAWS, STANDARDS, AND GUIDELINES.

⚠ WARNING: FOR EMERGENCY, LIFE SAFETY APPLICATIONS USING THE *SAFEPATH4* AUDIO BOOSTER, INSTALLATION, TESTING AND MAINTENANCE SHALL BE PERFORMED BY QUALIFIED PERSONNEL IN ACCORDANCE WITH ALL THE LATEST NATIONAL FIRE PROTECTION ASSOCIATION (NFPA), UNDERWRITER'S LABORATORY (UL), NATIONAL ELECTRIC CODE (NEC), OCCUPATIONAL SAFETY AND HEALTH ADMINISTRATION (OSHA), STATE, COUNTY, LOCAL, PROVINCE, DISTRICT, FEDERAL, AND OTHER APPLICABLE BUILDING AND FIRE STANDARDS, GUIDELINES, REGULATIONS, LAWS, AND CODES INCLUDING, BUT NOT LIMITED TO, ALL APPENDICES AND AMENDMENTS AND REQUIREMENTS OF THE LOCAL AUTHORITY HAVING JURISDICTION (AHJ).

It is recommended that the local AHJ inspect and approve the proposed placement of all the notification appliances.

Section 1-4 - Property Insurance Recommendation

The Voice Evacuation System containing the *SAFEPATH4* Audio Booster panel is not a substitute for insurance. All users should have adequate levels of life and property insurance.

Section 1-5 - Audio Output Considerations

⚠ WARNING: AUDIBLE SIGNALS MAY MASK MEDICAL EQUIPMENT MONITORING ALARMS. WHERE MEDICAL EQUIPMENT MONITORING ALARMS ARE IN USE, DO NOT USE AUDIBLE SIGNALS; PROVIDE VISUAL NOTIFICATION APPLIANCES IN HIGHLY VISIBLE LOCATIONS.

⚠ CAUTION: The output of the audio system may not be heard in all cases. Sound can be blocked or reduced by walls, doors, carpeting, wall coverings, furniture, insulation, bed coverings, and other obstacles that may temporarily or permanently impede the output of the audio system. Sound is also reduced by distance and masked by background noise. The output of the audio system may not be sufficient to alert all occupants, especially those who are asleep, those who are hearing-impaired, those who are wearing devices that plug or cover the ears, and those who have recently used drugs or alcohol. The output of the audio system may not be heard by an alert person if the output device is placed in an area which is isolated by a closed door, or is located on a different floor from the person in a hazardous situation or is placed too far away to be heard over ambient noise such as, but not limited to, running water, traffic, air conditioners, machinery or musical appliances.

If live microphone announcements, audible tones and/or voice messages cannot be readily heard and understood clearly within the protected areas as intended, it will be necessary to increase the number and/or sound output intensity of speakers within those areas so that they are heard and understood clearly when activated.

Section 1-6 - RF Interference

The **SAFEPAH4 Audio Booster** panel has been tested and found to comply with the limits for a Class A digital device, pursuant to Part 15 of the FCC Rules. These limits are designed to provide reasonable protection against harmful interference when the equipment is operated in a commercial environment. This equipment generates, uses, and can radiate radio frequency energy and, if not installed and used in accordance with the instruction manual, may cause harmful interference to radio communications. Operation of this equipment in a residential area is likely to cause harmful interference in which case the user will be required to correct the interference at his own expense.

Section 1-7 - General

Each manufacturer's fire alarm control panel and notification appliances operate differently and have different features. Before specifying, installing, operating, testing, maintaining or servicing a system, carefully read the installation, operation and testing manual for each piece of equipment and applicable codes.

Additional copies of this manual may be obtained from:

Wheelock, Inc.
273 Branchport Ave.
Long Branch, N.J. 07740
Tel: (800) 631-2148
Fax: (732) 222- 2588
E-mail: info@wheelockinc.com

Intentionally Blank

Chapter 2 - Overview and Features

Section 2-1- Description

General

The SAFEPATH4 AUDIO BOOSTER panel provides additional or remote amplification for Wheelock, Inc. Voice Evacuation panels. It is designed to boost the capacity of the SP40/2 panel by increasing the output wattage of the 25V or 70.7V audio output. There are two models of the audio booster. Model SPB-80/4 contains an 80 Watt, 25V or 70.7V, supervised audio output with two supervised and synchronized selectable 2 Amp strobe outputs. Model SPB-160 contains 160 Watt amplifier section with two 80 watt outputs each of 25V or 70.7V selectable supervised audio outputs. The SPB-160 does not contain strobe NAC circuits. Figures 2-1 and 2-2 on Page 15 illustrate the basic capabilities.

NOTE: Input and Output audio must be the same throughout the entire system. If 25V is selected as the input voltage, then 25V must be selected as the output voltage for the entire system. If 70.7V is selected as the input voltage, then 70.7V must be selected as the output voltage for the entire system.

The voice evacuation panel and the audio booster panel **do not** sense an emergency condition or hazards such as fire; it is only a part of a system that does sense such conditions. The panel, when activated by a voice evacuation panel, provides an amplified audio output from the voice evacuation panel to speaker notification appliances. When used as part of a protective signaling system, the voice evacuation panel must be properly connected to a compatible control panel that has been approved by a nationally recognized testing laboratory ("LISTED") and to LISTED compatible notification appliances for proper operation.

THE SAFEPATH4 AUDIO BOOSTER PANEL MUST BE PROPERLY INSTALLED AND CONNECTED TO A PROPERLY INSTALLED SP40/2 VOICE EVACUATION PANEL IN ORDER TO FUNCTION IN A VOICE EVACUATION SYSTEM.

Section 2-2 - Enclosure and Configuration

See Chapter 8 for Technical Specifications

Section 2-3 - Nominal Electrical Data

See Chapter 8 for Technical Specifications.

Section 2-4 - Operation Modes

Standby Mode

Standby is the normal mode. The panel supervises the connections and internal components to maintain proper operation. All speaker appliances are off. If AC power is lost, the panel goes into a sleep or reduced power mode to conserve battery power.

Alarm Mode

Alarm mode occurs when an emergency signal is initiated by the voice evacuation system through an FACP or control equipment.

Standard Features

Table 2-1 Standard Features

Feature	SPB-80/4	SPB-160
Strobe Input Circuit	Power limited 8-33VDC NAC or CC strobe Activation	No Strobe Circuits.
Strobe Output Circuit	Two - 24VDC, 2A Max NAC Supervised power limited strobe outputs. Selectable Outputs: Wheelock Sync, Wheelock Pass Through, or Constant DC. Trouble LED's for open and short output conditions Supervised with 10K Ohm EOLR.	
Audio Input Circuit	One 1.2 Watt 25V or 70.7V input	One 1.2 Watt 25V or 70.7V input
Audio Output Circuit	One 80 Watt, 25V or 70.7V selectable, supervised, power limited audio output. Trouble LED's for open and short output conditions. Supervised with 10K Ohm EOLR.	Two 80 Watt, 25V or 70.7V selectable, supervised, power limited audio output. Trouble LED's for open and short output conditions. Supervised with 10K Ohm EOLR.
Battery Standby Sleep Mode	When Audio Booster is in the standby mode and is on battery backup, the amplifier section shuts down to conserve battery power. The Two Wire Mode also shuts off non-alarm functions on the SP40/2. When an alarm signal sends a message to the Audio Booster the amplifier section is reenergized and broadcasts the message. The Four Wire Mode allows non-alarm functions on the SP40/2. An Auxiliary NAC/CC input wakes the Audio Booster for broadcast.	
Power Supply Section	120VAC, 3.8A, 50-60Hz input 24VDC, 12AH Battery Backup 24VDC, 0.5A Power Output for Splitter Connections	
Ground Fault Detection	Monitors inputs and outputs for 600K Ohms minimum in relation to ground.	
Supervision	Full supervision with on-board diagnostics and trouble reporting circuits for: Audio NAC circuit wiring — open and short conditions Ground Fault detection Strobe NAC circuit wiring — open and short conditions Amplifier — operation Input voltage/low battery	
Trouble Reporting	Form C relay trouble contacts for external notification.	

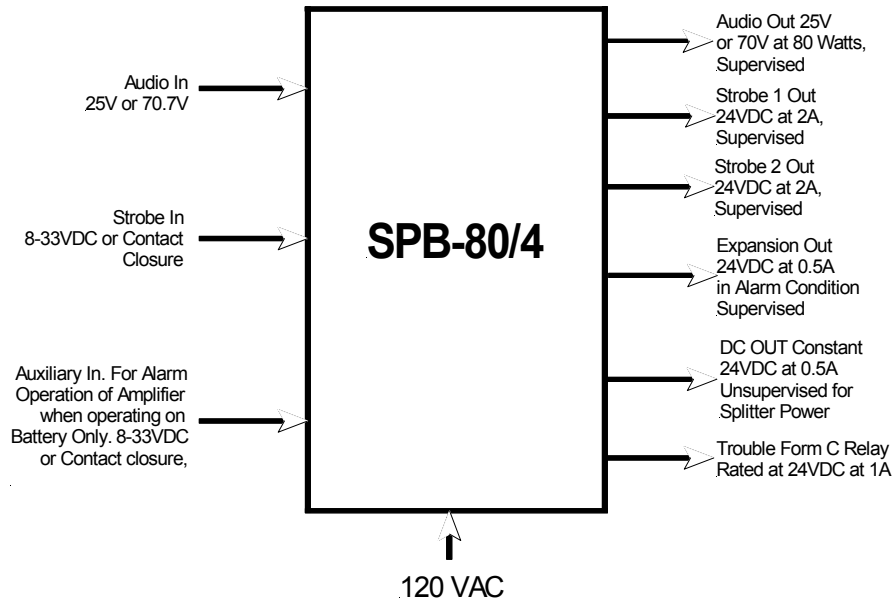

Figure 2-1
Basic Capabilities of the SPB-8/40 SAFEPATH4 Audio Booster Panel

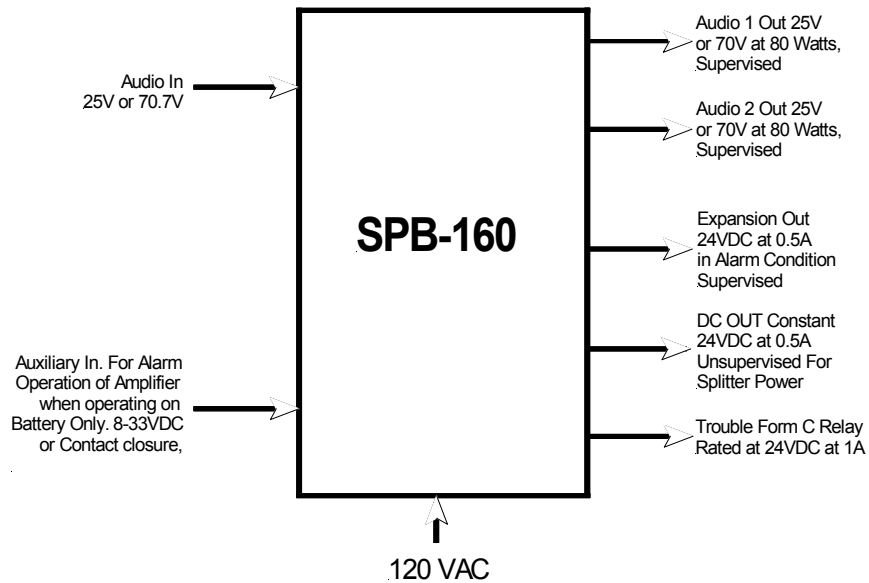

Figure 2-2
Basic Capabilities of the SPB-160 SAFEPATH4 Audio Booster Panel

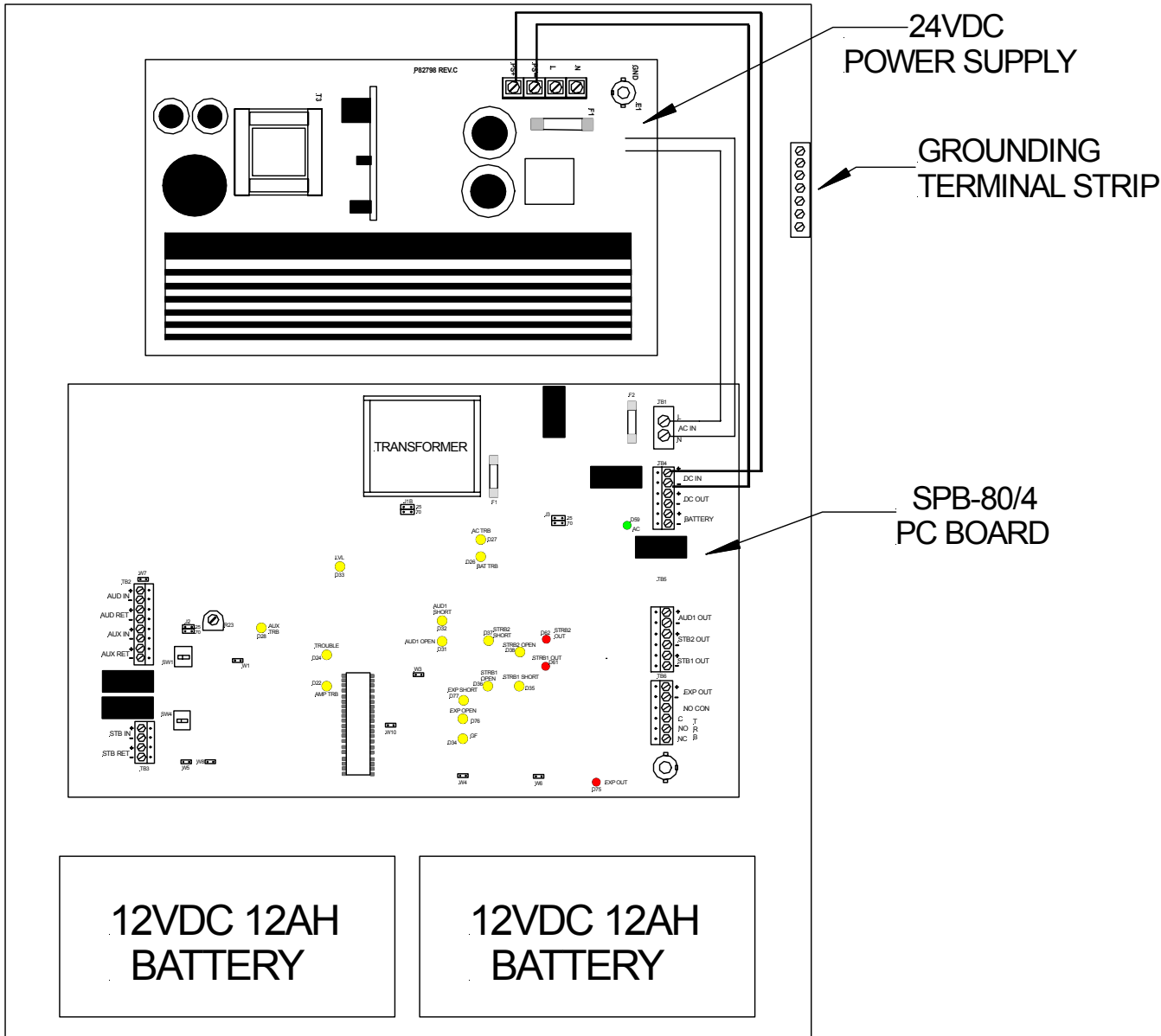

Figure 2-3
Layout of SPB-80/4 SAFEPATH4 Audio Booster Panel

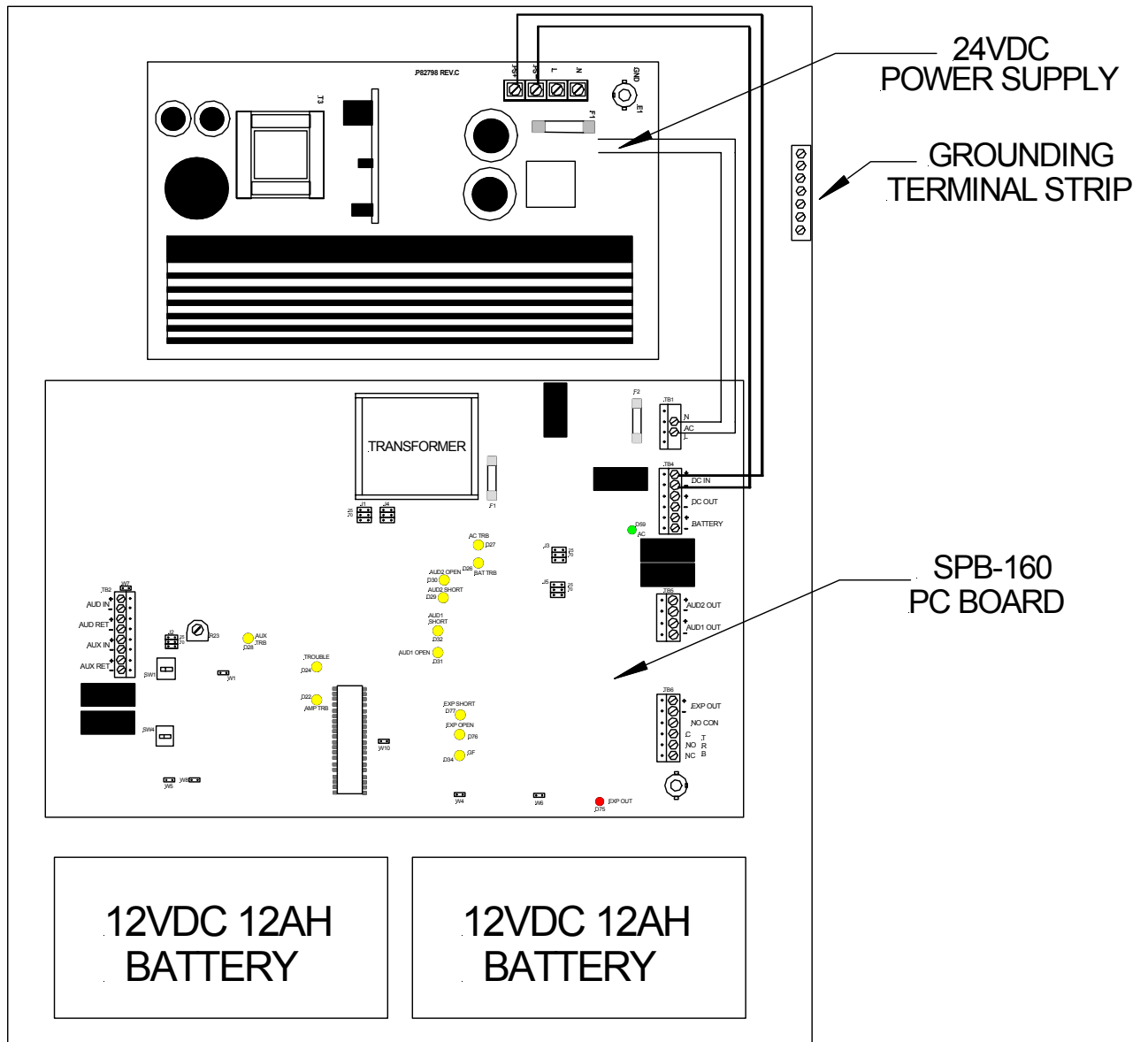

Figure 2-4
Layout of SPB-160 SAFEPATH4 Audio Booster Panel

Intentionally Blank

Chapter 3 - Installation and Setup

Section 3-1 - Introduction

The lives of people depend upon your safe and proper installation of the voice evacuation system and the Audio Booster Panel. Please read, understand and carefully follow the specific installation instructions set forth below to avoid damage to the panel and equipment connected to it. Only qualified personnel in accordance with the procedures in this manual should conduct installation.

⚠ WARNING: SHUT OFF ALL POWER BEFORE STARTING THE INSTALLATION. ELECTRICAL SHOCK CAN CAUSE DEATH OR SERIOUS INJURY.

⚠ WARNING: DO NOT CONNECT AC POWER OR BATTERY BACKUP POWER UNTIL SYSTEM WIRING HAS BEEN CONNECTED, MODULES HAVE BEEN INSTALLED, AND FIELD WIRING HAS BEEN INSPECTED.

⚠ CAUTION: The printed circuit board is sensitive to static electricity and has delicate components mounted on it. Before handling the board or any component on it, discharge any static electricity from your body by touching a grounded object such as a metal screw, which is connected to earth, ground. The panel is to be installed in a static free area and the user is to properly attach grounded wrist straps before touching any static sensitive areas.

The installer, prior to installation should consult with the authorities having jurisdiction (AHJ).

Section 3-2 – Two Wire and Four Wire Audio Modes

Modes

There are two modes of operation for the audio input. These modes are: Two Wire and Four Wire. A maximum of 33 Audio Booster panels can be connected to an SP40/2 panel.

The Two Wire Audio Mode is used with the Wheelock, Inc. SP40/2 voice evacuation panel. Supervision of the audio booster is performed over the same two wires used by the audio input signal. If any one audio booster connected in the system goes into trouble, all secondary operations (background music (BGM), telephone paging, and night ring) will disengage from all audio boosters connected in the system. This method conserves battery backup power, if AC power is lost. When an alarm message or a live voice message from the microphone is broadcast by the SP40/2, the audio booster is amplifier section is energized and the message is broadcast.

Connecting 1 to 33 Audio Booster panels to an SP40/2 in the two wire mode is done by connecting the audio returns (AUD RET) to the next audio input (AUD IN), and placing the UL Listed 10K Ohm EOLR on the last AUD RET. Jumper W10 shall be installed. This is illustrated in Figure 3-1.

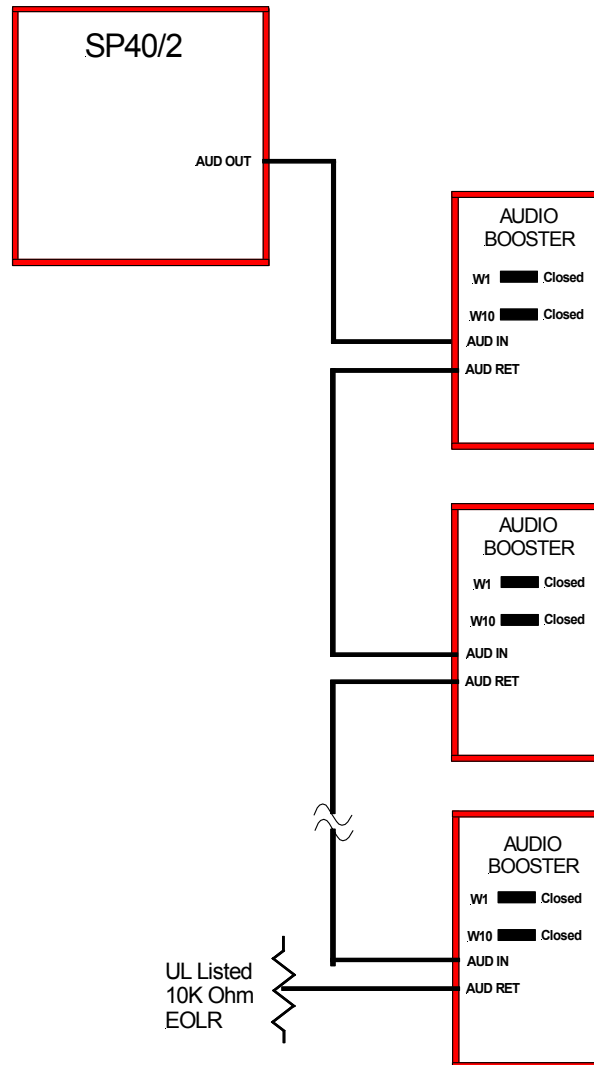

Figure 3-1
Connections for Multiple Audio Booster in Two-Wire Mode

The Four Wire Audio Mode is used when multiple Audio Boosters are used on the output of the SP40/2 and it is not desirable to lose secondary operations when a single audio booster goes into trouble. Only that Audio Booster will lose secondary operations. An 8-33VDC NAC or a contact closure applied to the AUX IN terminals will energize the Audio Booster on battery backup and have it broadcast the message.

Connecting 1 to 33 Audio Booster panels to an SP40/2 in the four wire mode is done by connecting the audio output (AUD OUT) from the SP40/2 to the master Audio Booster panels audio input (AUD IN). The UL Listed 10K Ohm EOLR shall be placed on the last Audio Booster AUD RET. Connecting multiple Audio Booster panels is illustrated in Figure 3-1.

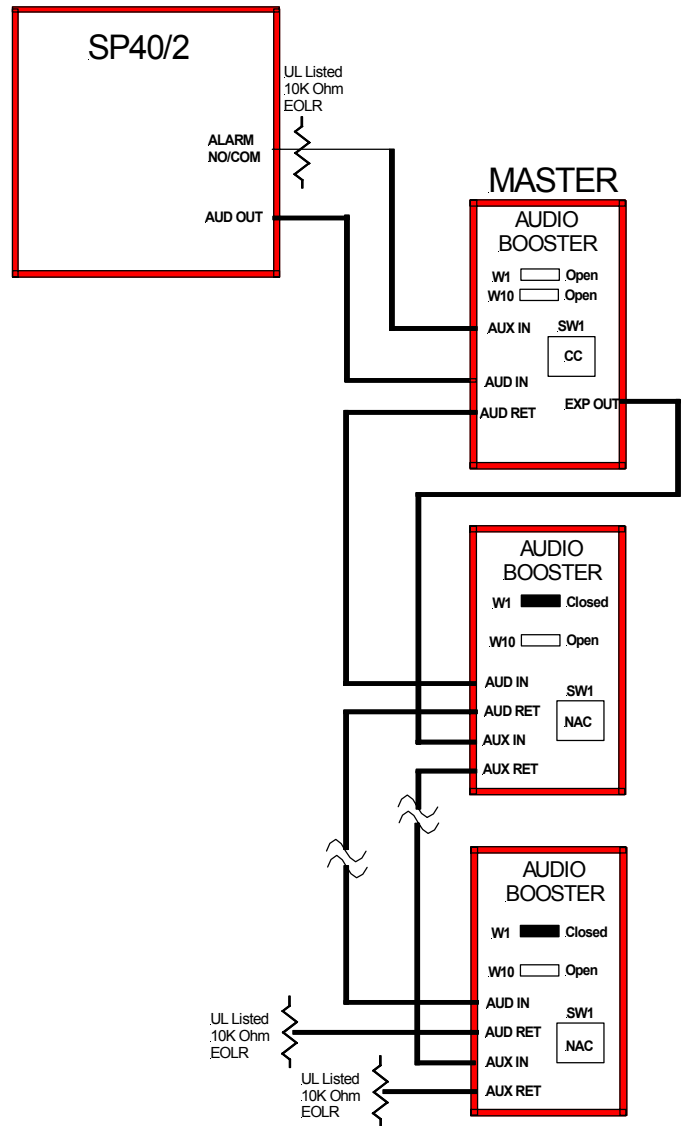

Figure 3-2
Connections for Multiple Audio Booster in Four-Wire Mode

On the master Audio Booster panel, connect the SP40/2 “normally open” and “common” alarm relay connections to the AUX IN connections. Connect a UL Listed 10K Ohm EOLR across the SP40/2 Alarm Relay connections. Place the switch SW1 in the “CC” position. Remove jumper on W1 and W10.

Connect the EXP OUT on the master Audio Booster to the AUX IN of the second Audio Booster. Connect the AUX RET to the next Audio Booster AUX IN and continue to the last Audio Booster. Connect the UL Listed 10K Ohm EOLR on the last AUX RET on the last Audio Booster.

On Audio Booster panels 2 through 33, set SW1 to NAC. Insure jumper W1 is in place. Remove jumper W10.

NOTE: When the contact closure is used in the 4-wire mode, jumper W1 shall be removed on the master Audio Booster and installed on subsequent Audio Booster panels. If jumper W1 is removed and an EOLR is not installed the TROUBLE LED D24 and the AUX TRB LED will be lighted.

Section 3-3 - General Installation Instructions

Refer to Figure 3-3A and 3-3B on Pages 23 and 24 which shows the location of wiring connections used in the installation of the panel. Table 3-1 on Page 25 explains the functions of the different wiring connections.

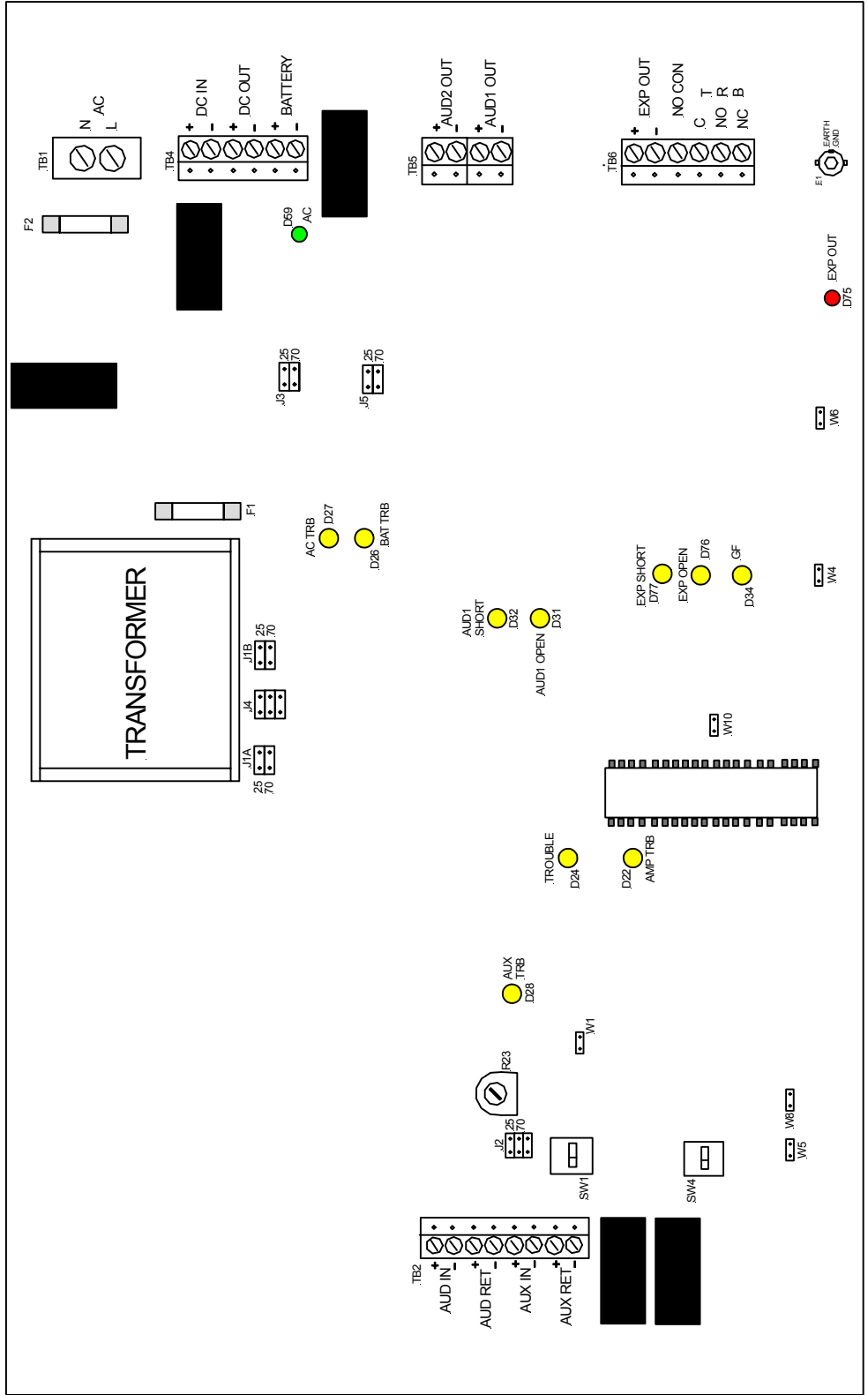

Figure 3-3A
Location of Field Wiring Connections
SPB-160

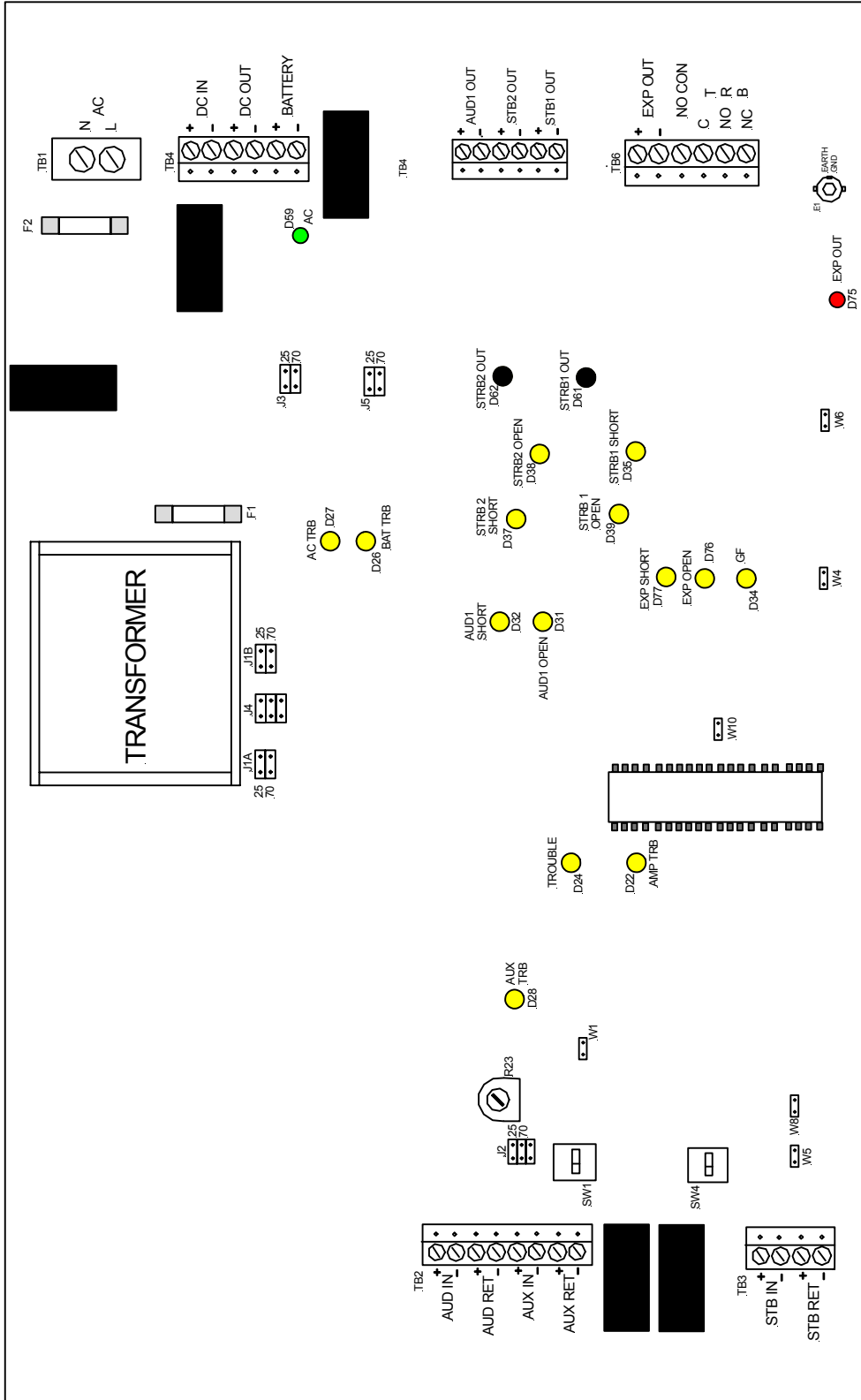

Figure 3-3B
Location of Field Wiring Connections
SPB-80/4

**Table 3-1
Terminal Connection Definitions**

	Symbol	Full Name	Definition
TB1		Terminal Block 1	
	AC IN	AC sensing Input Connection	Factory connection senses proper AC Voltage input. Low AC or no AC input will light the AC LED and cause a trouble condition.
TB2		Terminal Block 2	
	AUD IN	Audio Input	25V or 70.7V power limited audio input. Blocking capacitor for DC Supervision. Power consumption is 1.2 Watts.
	AUD RET	Audio Return	Audio Input Return. Used to continue Audio Circuit from the voice evacuation panel, connecting additional audio boosters, or voice evacuation panel's EOLR.
	AUX IN	Auxiliary Input	8 to 33VDC (10mA) NAC power limited source or contact closure input. Used in the Four Wire mode. Applying an alarm input restores audio booster to full power from the power saver mode when panel is in battery backup mode. Reverse Polarity.
	AUX RET	Auxiliary Return	8-33VDC (10mA) NAC power limited source (only) Auxiliary input return. Used to connect to additional audio boosters through the voice evacuation panel.
TB3		Terminal Block 3	
	STB IN	Strobe Input (SPB-80/4 Only)	Power limited 8 to 33VDC (10mA) NAC power limited source or contact closure input. Initiates Strobe Outputs on the SPB-80/4 only. Reverse Polarity.
	STB RET	Strobe Return (SPB-80/4 Only)	Strobe Input Return - Used to continue strobe input circuit, connecting additional strobe input circuits from audio boosters, Strobe appliances or voice evacuation panel's EOLR.
TB4		Terminal Block 4	
	DC IN	DC Input	Factory wired 24VDC Input from power supply (SAPS)
	DC OUT	DC Output	24VDC at 0.5A, non-power limited used for splitter power only.
	BATTERY	Battery	24VDC Battery connection for battery charging and battery backup.
TB5		Terminal Block 5	
	AUD2 OUT	Audio 2 Output (SPB-160 Only)	Audio Output #2 - Provides 25V or 70.7V, power limited audio output at 80 watts. Supervised using a UL Listed 10K Ohm EOLR.
	AUD1 OUT	Audio 1 Output	Audio Output #1 - Provides 25V or 70.7V power limited audio output at 80 watts. Supervised using a UL Listed 10K Ohm EOLR.
	STB2 OUT	Strobe 2 Output (SPB-80/4 Only)	24VDC at 2.0A NAC power limited Supervised using a UL Listed 10K Ohm EOLR.
	STB1 OUT	Strobe 1 Output (SPB-80/4 Only)	24VDC at 2.0A NAC power limited Supervised using a UL Listed 10K Ohm EOLR.
TB6		Terminal Block 6	
	EXP OUT	Expansion Out	24VDC at 0.5A power limited circuit energized when a signal is applied to AUX IN or Strobe In. Reverse polarity Supervised using a UL Listed 10K Ohm EOLR.
	TRB	Trouble	Form C relay rated at 24VDC at 1.0A. Used for external trouble reporting.

Unpack and Inventory

- Carefully unpack the panel and make sure each item described on the packing slip is present and undamaged.

Mounting

- Mount the panel and optional expansion modules in the desired locations as described in Section 3-5 (Page 34).
- Mount any additional wiring boxes or junction boxes needed to interconnect field wiring.
- Connect conduit fittings or bushings as needed through the knockouts provided on the top and bottom of the panel.

Field Wiring Connections

NOTE: The terminal blocks on the Audio Booster are removable. To remove a terminal block, pull the block straight up from the circuit board, as shown in Figure 3-4. Attach wires to the desired connections, then plug the terminal block back on the board being careful to match the pins.

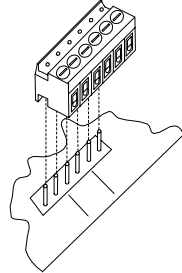

Figure 3-4
Removable Terminal Block

4. Install field wiring in conduit when required, following the most current National Electrical Code (NFPA-70) and local codes for the type of system being installed. Make all necessary connections at any additional wiring or junction boxes. Separate power limited and non-power limited wires. Wiring shown in Figure 3-5 is recommended.

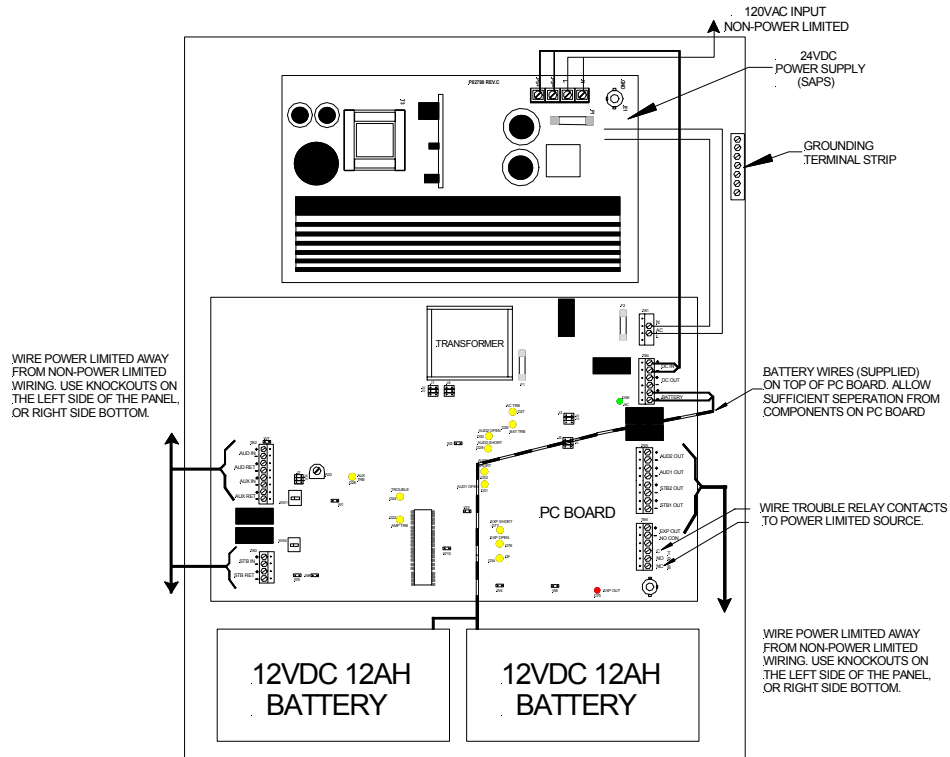

Figure 3-5
Power Limited and Non-Power Limited Wiring

CAUTION: Provide proper strain relief for all wiring not in conduit.

NOTE: Shielded wire is not required on any circuit. If shielded wire is used, connect the shields to the ground terminal strip.

Audio and Auxiliary Input Connections

The audio input circuit (AUD IN) consists of either the power limited 25V or 70.7V circuit of the SP40/2 panel. The input uses a blocking capacitor for DC supervision. The audio return (AUD RET) can be used to link other *SAFEPATH4* Audio Boosters to the host voice evacuation panel, additional speakers powered by the host panel, or connecting the host panels EOLR.

The auxiliary input circuit is used to trigger the *SAFEPATH4* Audio Booster to return to full power from a reduced power mode when operating on the backup battery supply. The input can be selected to be a power limited 8-33VDC NAC circuit or a contact closure. This is selected by switching SW1. The AUX RET is used to link additional Audio Boosters to the Auxiliary Circuit or connecting the host panel's EOLR.

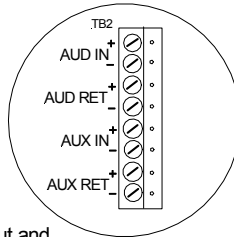

Audio Input and
Battery Wakeup Mode

Figure 3-6

Audio and Auxiliary Input Connections (SPB-160 and SPB-80/4)

1. Connect the audio output from the voice evacuation panel to the AUD IN terminals. Connect the SP40/2 panel's EOLR to the AUD RET terminals.
2. Select the proper audio input voltage, using jumper J2 (Input Voltage Select). Location of the jumper is shown in Figure 3-19A and Figure 3-19B on page 36.

⚠ CAUTION: Input and Output audio voltages shall be matched. If a 25V is selected as the input voltage, then 25V shall be selected as the output voltage.

3. Connect the NAC or Contact Closure input to the AUX IN terminals. Connect the voice evacuation panel's EOLR to the AUD RET terminals.

Strobe Input Connections

The strobe input circuit (STB IN) consists of either a power limited 8-33VDC NAC circuit input or a contact closure input. The input user reverse polarity for supervision. The strobe return (STB RET) can be used to link other *SAFEPATH4* Audio boosters strobe NAC circuits to the host voice evacuation panel, additional strobes powered by the host panel, or connecting the host panels EOLR.

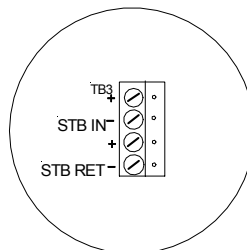

Strobe Input and
Strobe Return

Figure 3-7

Strobe Input Connections (SPB-80/4)

1. Connect the strobe input to the STB IN terminals. Connect the proper device or connection to the STB RET.

Audio and Strobe Output Circuit Connections

NOTE: A UL Listed 10K Ohm EOLR shall be installed on both AUD1 and AUD2 outputs for supervision whether they are used or not. If the audio circuit is used, the UL Listed 10K Ohm EOLR shall be placed on the last audio appliance on the circuit. Failure to do so will cause an open condition causing the TROUBLE LED D24 to turn on as well as the respective OPEN LED to light.

NOTE: AUD1 and AUD2 are two separate 80 watt, Class B, power limited audio output circuits. Do not wire AUD1 and AUD2 together.

NOTE: STB1 and STB2 are two separate 2 Amp, Class B, power limited strobe NAC circuits. Do not wire STB1 and STB2 together.

Figure 3-8 shows the audio and strobe output connections as they are on the SPB-80/4. Notice that there is two strobe outputs.

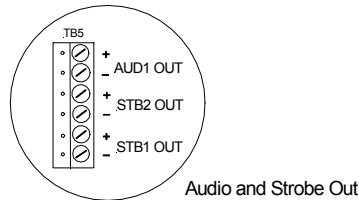

Figure 3-8
Audio and Strobe Output Connections (SPB-80/4)

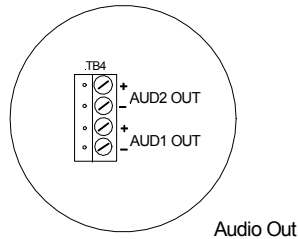

Figure 3-9
Audio Output Connections (SPB-160)

1. Connect Audio Appliance circuit to Audio Output (AUD OUT) connection(s). Figure 3-8 and Figure 3-9 are enlarged diagrams of the referred areas. The Audio Output(s) is supervised. A UL Listed 10K Ohm, EOLR is required at the end of the circuit for proper supervision.
2. For the SBP-80/4, select the proper output voltage (25V or 70V) using the Audio Output Select Jumper J1B and J3. See Figure 3-19B (Page 36) for location.
3. For the SPB-160, select the proper output voltage (25V or 70V). Use Jumpers J1A and J3 for AUD1 and Jumpers J4 and J5 for AUD2. See Figure 3-19A (Page 36) for location.
4. Connect Strobe Appliance circuit to STB Outputs (STB1 OUT, STB2 OUT) connections. Figure 3-8 is an enlarged diagrams of the referred area. The strobe outputs are supervised. UL Listed 10K Ohm, EOLR is required at the end of the circuit for proper supervision.
5. Select the proper strobe-operating mode (Wheelock Sync, Wheelock Pass through Sync, or 24VDC constant using the Strobe Sync Select Jumper W5. See Figure 3-19B (Page 36) for location.

NOTE: Input and Output audio voltages shall be matched. If a 25V is selected as the input voltage, then 25V shall be selected as the output voltage.

Expansion Output and Trouble Contact Connections

The purpose of the Expansion Output (EXP OUT) is to provide a 24VDC at 0.5A supervised, power limited output when the Audio Booster audio output is operating. This allows additional Audio boosters to be connected by having the EXP OUT connect to the AUX IN of the next Audio Booster. The strobe input circuit on an SPB-80/4 will not cause the expansion output to energize.

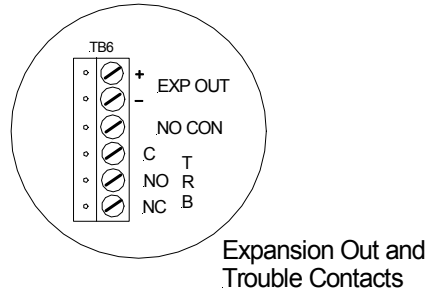

Figure 3-10
Alarm and Trouble Connections (SPB-160 and SPB-80/4)

The Trouble relay changes state whenever a trouble condition occurs on the Audio Booster circuit board and when the TROUBLE LED D24 lights. As shown in Figure 3-10, connecting to the common terminal (C) and the normally open terminal (NO) would prevent current flow through the relay contacts in the normal operating condition. A trouble condition will cause the relay to switch states allowing current to flow. When there is no power (DC IN or BATTERY) the common and normally open contacts will be shorted.

1. If required connect the Expansion Out. Ensure that a UL Listed 10K Ohm EOLR is connected for supervision.
2. Connect External Trouble circuit to the proper Trouble (TRB) connections.
3. Connect the panel to earth ground, following the National Electrical Code (NEC) and local codes for the type of system being installed. Wire gauge selection of the earth ground wiring should involve consideration of all factors, including maximum allowable wire resistance and length. The panel is tied to earth ground by connecting the ground terminals to an earth ground. The location of the ground terminal strip within the panel is shown in Figure 3-18 for both the SPB-160 and the SPB-80/4 (Page 35).

Power and Battery Connections

Wiring to the DC IN is factory installed from the Power Supply Module (SAPS).

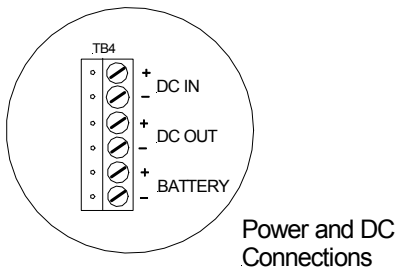

Figure 3-11 Power and Battery Connections

NOTE: DC OUT is a 24VDC at 0.5A output for powering splitter modules only. .

BATTERY terminals are used to connect the backup batteries to the panel for recharging and backup power. The UL approved battery connection is 24VDC at 12AH. See Figure 3-11.

⚠ CAUTION: Do not connect input voltage to any equipment until the field wiring has been tested, inspected and approved.

1. Check the integrity of all field wiring. Confirm that specified wiring is installed, and that there is continuity between required points (no open circuits), with no unwanted shorts to other conductors, chassis, or earth ground.
 - a. Verify that the field wiring complies with the instructions of this manual and the detailed wiring diagram prepared for this installation.
 - b. Ensure that no unwanted voltages are present on circuit conductors and ground.
 - c. Test all ungrounded connectors for electrical isolation from ground.
 - d. Measure and record the resistance of each NAC circuit. Conduct this test reversing polarity.
2. Calculate and Install properly sized backup batteries as described in Section 3-8 (Page 38) and 3-9 (Page 40). The *SAFEPATH4* Audio Booster is UL approved for 24VDC at 12AH.
3. Perform **System Checkout** Procedures as described in Section 3-6 System Checkout on Page 35.

⚠ WARNING: TWO DIFFERENT SOURCES OF POWER MAY BE CONNECTED TO THIS UNIT. DISCONNECT BOTH SOURCES OF POWER BEFORE SERVICING. FAILURE TO DISCONNECT BOTH POWER SOURCES BEFORE SERVICING COULD RESULT IN PROPERTY DAMAGE, SERIOUS INJURY, OR DEATH TO YOU AND/OR OTHERS.

⚠ WARNING: ALWAYS APPLY AC VOLTAGE BEFORE APPLYING BATTERY BACKUP VOLTAGE. FAILURE TO DO SO MAY CAUSE DAMAGE TO THE PANEL.

Section 3-4 – Panel Wiring

Wiring Guidelines

Although the panel incorporates signal verification and noise filtering circuitry on their inputs, induced voltages or noise on the input wiring can cause improper operation. Therefore, use shielded twisted pair wire for all dry contact input wiring.

The shield of each cable shall be connected only at one end. Each shield of each cable that connects to the panel is to be connected to the grounding points provided near the knockout locations on the chassis (see Figure 3-18 on Page 35).

The National Electrical Code defines two types of circuits for protective signaling systems: **power limited** circuits and **non-power limited** circuits. All outputs (AUD1 OUT, AUD2 OUT, STB1-OUT, STB2-OUT and EXP OUT) are **power-limited** circuits. AUD-IN with 25V or 70.7V input and STB-IN, AUX IN and TROUBLE CONTACTS with 8VDC to 33VDC inputs shall be connected to a power limited source. AC, BATTERY and DC OUT are non-power limited circuit.

⚠ WARNING: ALL *SAFEPATH4* AUDIO BOOSTER AUDIO WIRING SHOULD BE ROUTED AWAY FROM ANY HIGH VOLTAGE OR HIGH CURRENT WIRING (SUCH AS AC OR DC POWER WIRING, AUDIO POWER WIRING, AND MOTOR OR RELAY ACTUATION WIRING). FAILURE TO DO SO MAY CAUSE ELECTRICAL SHOCK RESULTING IN PROPERTY DAMAGE AND SERIOUS INJURY OR DEATH TO YOU AND/OR OTHERS.

⚠ CAUTION: The National Electric Code limits the maximum number of conductors that can be installed in conduit and wiring boxes depending on the size of the conduit, the volume of the boxes, and the gauge of the wire used. Make sure that wiring used for installation complies with the latest NEC, NFPA, Local, State, County or Province requirements.

Field Wiring Connections

All wiring terminals are designed to accept #12 AWG through #18 AWG wiring for one wire per terminal or #16 AWG to #18 AWG for two wires per terminal. Proper wire gauge considerations for the Notification Circuit must take into account current requirements versus length of run.

NOTE: Only speakers with DC blocking capacitors will provide for proper speaker supervision.

Visual Notification Appliance Output Wiring (SPB-80/4)

Wire gauge selection involves consideration of all factors including, wire loop length, maximum current draw of each appliance, number of appliances, and maximum voltage drop allowable.

The SPB-80/4 has two strobe NAC circuits, while the SPB-160 has none.

- Each strobe NAC has a 24VDC, 2.0 Amps maximum output.
- Strobe NAC meets Class B supervision requirements for notification appliance circuits.
- The strobe output circuit shall have a UL Listed 10K Ohm, EOLR installed across the last visual notification appliance. If the output is unused, a UL Listed 10K Ohm, EOLR shall be placed across the output terminals.

Speaker Notification Appliance Output Wiring

Wire gauge may vary for each audio appliance output on the panel. When:

- Speaker (with transformer) appliances are used with supervised audio amplifier module. Wire gauge selection should involve consideration of all factors including, wire length, appliance power ratings, and the number of appliances.
- The two amplified outputs are either a selectable 25V or 70.7V audio output, rated for 80 watts maximum. The SPB-80/4 has one audio output, while the SPB-160 has two.
- The output meets Class B supervision requirements for notification appliance circuits.
- The audio output circuit shall have a UL Listed 10K Ohm, EOLR installed across the last notification appliance. If the output is unused, it shall have a UL Listed 10K Ohm, EOLR across the output terminals.

Wiring Diagrams for Notification Appliances

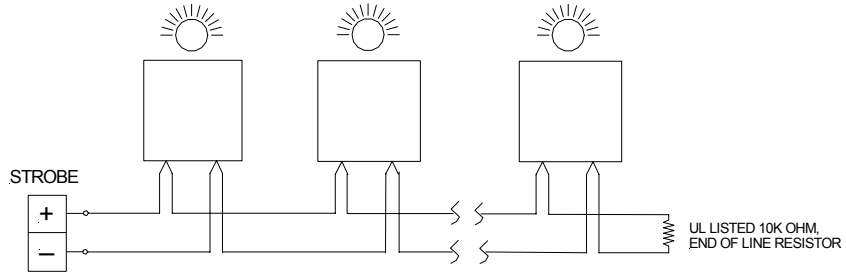

Figure 3-12
Wiring Diagram for Visual Only Notification Appliances (SPB-80/4 Only)

⚠ CAUTION: Do not loop wire under terminals. Break wire run to provide supervision of the connection.

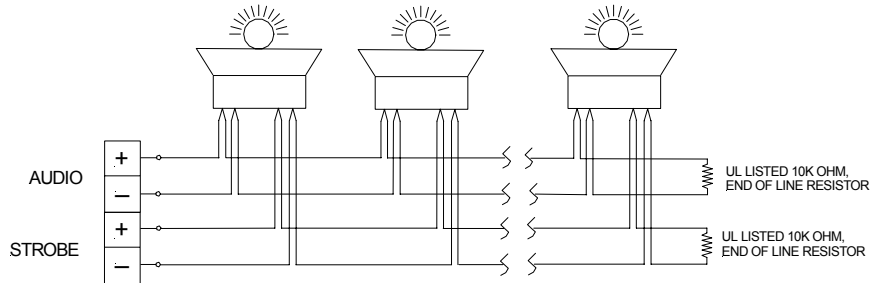

Figure 3-13
Wiring Diagram for Combination Audio/Visual Notification Appliances (SPB-80/4 Only)

⚠ CAUTION: Do not loop wire under terminals. Break wire run to provide supervision of connection.

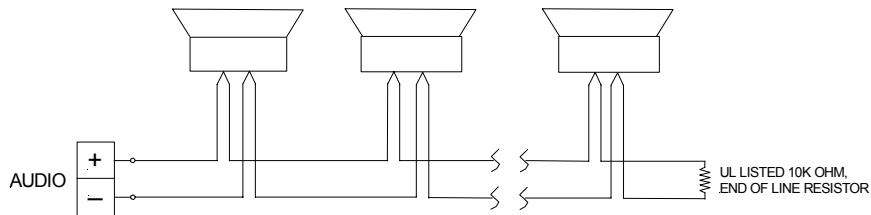

Figure 3-14
Wiring Diagram for Audio Only Notification Appliance Output

⚠ CAUTION: Do not loop wire under terminals. Break wire run to provide supervision of connection.

Trouble Output Contact Wiring

The locations of the Trouble Status Output Connections are shown in Figure 3-3A and Figure 3-3B Section 3 (Page 23 & 24). A magnified view of this area on the Mother Board is shown in Figure 3-3A and Figure 3-3B on Page 23 & 24.

- Wire gauge selection of the system Trouble Status output contact wiring should involve consideration of all factors including, wire length, maximum current capacity, and maximum voltage drop allowable.
- The system Trouble Status output contact is Form C, rated for 1.0 amps at 24VDC, resistive load.
- For a detail of the system Trouble Status output contact terminal connections (shown in the trouble position), see Figure 3-15.

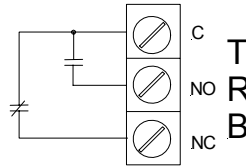

Figure 3-15
Trouble Status Relay Contacts

POWER CONNECTION REQUIREMENTS

The Audio Booster Panel contains a 24VDC Power Supply (SAPS). Batteries are charged from battery charger located on the Audio Booster PC Board. Connect the AC input power to the Line (L) and Neutral (N) terminals on the Power Supply PC Board (SAPS) as shown in Figure 3-12 below. Connect the battery to the BATTERY terminals on the Audio Booster PC Board shown in Figure 3-16. The DC OUT on the Audio Booster is used to power the splitter modules only. Calculate proper backup battery requirements using Section 3-8 – Battery Care and Backup Battery Calculations (Page 38). Section 3-9 on Page 40 is the AC and battery installation procedures.

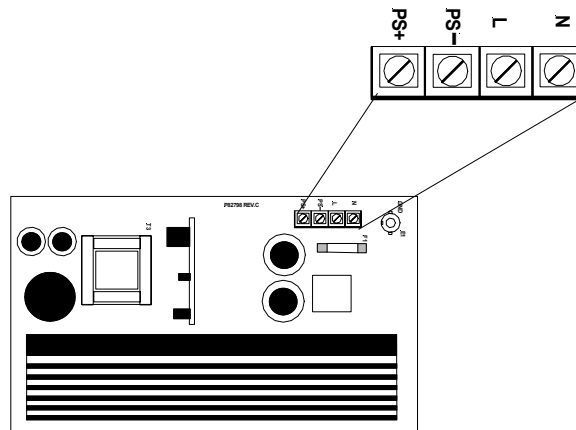

Figure 3-16
Input Power Connection Location on the SAPS Power Supply

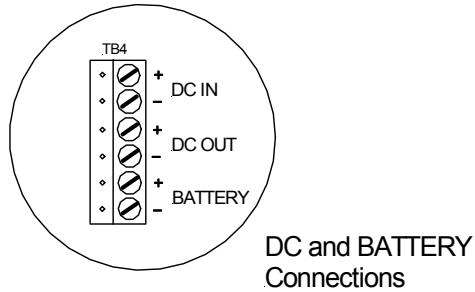

Figure 3-17
DC and Battery Connection on the Audio Booster PC Board

Section 3-5 - Mounting

Location

⚠ CAUTION: The panel shall be mounted in a location within the environmental limits specified in the latest UL Standard 864 for indoor control panels. The panel shall not be located in a hazardous area.

1. See Figure 3-18 on page 35, for panel mounting hole layout.
2. Mark and drill mounting holes for appropriate screws and anchors to ensure secure mounting to the type of surface at the selected location.
3. Prevent dust and dirt contamination of the **SAFEPATH4 Audio Booster** panel during installation. This contamination can interfere with the operation and reduce the life of the equipment.
4. Open the door and mount the **SAFEPATH4 Audio Booster** panel at the selected location. **Use care to avoid damage to the module during installation.** Do not apply excessive pressure to the PC board or its components, including field wiring terminals and connectors.

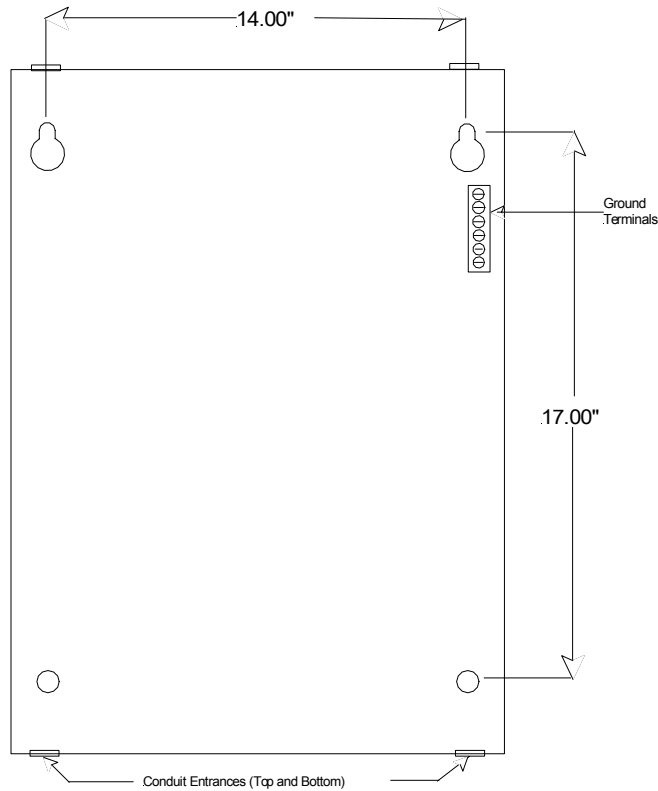

Figure 3-18
SAFEPATH4 Audio Booster Panel Mounting and Grounding Location

Section 3-6 - System Checkout

Refer to NFPA 72 (1999 Edition) for guidelines on testing notification systems.

System Control Settings

Figure 3-19A (SPB-80/4) and Figure 3-19B (SPB-160) on Page 36 shows the location of the different jumpers, switches, and variable resistors used to configure the Audio Booster. Table 3-2, page 37, explains the functions of the different jumpers, switches, and variable resistors. The following procedure is a basic setup for the panel:

1. Ensure that the AC and Battery Power **are not** connected.
2. Select the proper audio output (25V or 70V) by using the two jumpers (SPB-80/4 J1 and J3) (SPB-160 Audio 1 - J1 and J3, Audio 2 - J4 and J5)
3. Connect the speaker circuit(s) to terminal block TB5 **AUD OUT**. **Verify that the speaker circuit has a UL Listed 10K Ohm, EOLR.**
4. For SPB-80/4, if applicable, connect the strobe circuit to TB5 **STB1 OUT** and **STB2 OUT**. **Verify that the strobe circuit has a UL Listed 10K Ohm, EOLR.**
5. If Strobe synchronization is to be defeated, remove Jumper W5 Strobe Synchronization Defeat. (SPB-80/4 only)
6. If the Ground Fault feature is not desired, remove Jumper W6 Ground Fault Disable.

⚠ CAUTION: Input and Output audio voltages shall be matched. If a 25V is selected as the input voltage, then 25V shall be selected as the output voltage.

Table 3-2
Jumper/Switch/Variable Resistor Functions

Jumpers	Name	Description
W1	Auxiliary In CC EOLR Detection	Jumper in place – EOLR not detected Jumper removed – Detection enabled for 10K Ohm EOLR.
W4		Not Used - Jumper shall remain in place .
W5	Wheelock Sync Disable (SPB-80/4 Only)	Jumper in place – Wheelock Sync enabled. Jumper removed – Wheelock Sync disabled. Pass through sync or constant NAC enabled.
W6	Ground Fault Disable	Jumper in place – Ground Fault Circuit enabled. Jumper removed – Ground Fault Circuit Disabled.
W7	Audio Input Installed EOLR (For Wheelock Host Voice Evacuation Panel)	Jumper in place – Audio Input EOLR enabled. Jumper removed – Audio Input EOLR disabled.
W8		Not Used - Jumper shall remain in place .
W10	Shorted Audio Output Non Emergency Defeat	Jumper in place – Telephone Page, BGM, NR disabled. Jumper removed – Telephone Page, BGM, NR enabled
J1	Audio 1 Output Voltage Select	Selects Output Voltage 25V or 70V in conjunction with J3.
J2	Audio Input Select	Selects 25V or 70.7V for Audio input (AUD IN) by moving jumper.
J3	Audio 1 Output Voltage Select	Selects Output Voltage 25V or 70V in conjunction with J1.
J4	Audio 2 Output Voltage Select	SPB-160 Only. Selects Output Voltage 25V or 70V in conjunction with J5.
J5	Audio 2 Output Voltage Select	SPB-160 Only. Selects Output Voltage 25V or 70V in conjunction with J4.
Switches	Name	Description
SW1	Auxiliary In NAC/CC Select	Selects auxiliary input type 8-33VDC NAC or Contact Closure (CC). Switch depressed to the left for CC.
SW4	Strobe In NAC/CC Select	SPB-80/4 Only. Selects strobe input type 8-33VDC NAC or Contact Closure (CC). Switch depressed to the left for CC.
Variable Resistors	Name	Description
R23 (LVL)	Audio Input Volume Control	Adjusts audio input volume.

Checkout Procedure.

 **CAUTION:** Always connect the AC power source before connecting the battery backup power. Always disconnect the AC power source before disconnecting the battery backup power.

1. Connect AC power, then connect battery backup.

NOTE: When the AC power source is applied to the panel, the battery voltage check circuitry is activated. If batteries are not connected within 20 seconds the panel trouble circuit will be activated. The battery voltage check circuitry will re-check for batteries every 2 minutes. If the batteries are installed during the 2-minute period, the panel will remain in trouble until the next re-check.

D59 AC LED (Green) should be “ON” to indicate normal operation. If D24 TROUBLE LED (Yellow) is “ON”, a trouble condition is indicated. **STOP TESTING.** Refer to Chapter 7 of this manual, troubleshoot and correct the problem *before* you resume testing. See Figure 7-1A (SPB-160) and 7-1B (SPB-80/4) on Pages 49 and 50 for location of LEDs.

Perform the following tests:

Strobe Circuit Test (SPB-80/4 Only)

1. Switch SW4 to the CC position (depressed to the left). Short the STB IN terminals. Strobe Output Circuit should flash. Red LEDs D61 STB1 OUT and D62 STB2 OUT shall be lighted. Remove short.

Audio Output Test

1. Play a digital message or use the built in microphone on the SP40/2 voice evacuation panel and test the audio output circuit(s).

⚠ WARNING: ALL PROTECTIVE SIGNALING SYSTEMS REQUIRE PERIODIC TESTING. ALL PROTECTIVE SIGNALING SYSTEM EQUIPMENT SHALL BE TESTED BY QUALIFIED PERSONNEL AT LEAST TWICE A YEAR FOR PROPER OPERATION, OR MORE OFTEN IF REQUIRED BY CODES, REGULATIONS AND LAWS. FAILURE TO MAINTAIN AND TEST PROTECTIVE SIGNALING SYSTEM EQUIPMENT CAN RESULT IN NOT DETECTING EQUIPMENT FAILURE THAT CAN CAUSE PROPERTY DAMAGE AND SERIOUS PERSONAL INJURY OR DEATH TO YOU AND/OR OTHERS DURING AN EMERGENCY SITUATION.

Section 3-7 – Ground Fault Detection

Ground fault detection sensitivity is 600K Ohms for Class B, Style Y connections. If ground fault detection is not desired, remove jumper W6. See Figure 3-19A (SPB-160) and Figure 3-19B (SPB-80/4) on page 36 for location.

NOTE: The Ground Fault LED D34 may flicker while STB-IN is operated in Wheelock Pass-Through Mode (W5 removed). This **DOES NOT** indicate the presence of an actual Ground Fault Trouble.

Section 3-8 – Battery Care and Backup Battery Calculations

Care of Sealed Lead Acid Batteries

Sealed lead acid batteries are designed to operate in standby service for approximately five years. This is based upon a normal service condition where there is an ambient temperature of 20 degrees C (68 degrees F) and batteries are completely discharged once every three months. LENGTH OF SERVICE LIFE WILL BE DIRECTLY AFFECTED BY THE NUMBER OF DISCHARGE CYCLES, DEPTH OF DISCHARGE, AND AMBIENT TEMPERATURE.

Use Guidelines:

Avoid installation and/or operation in close proximity to heat sources. While the operating temperature range is 0 to 49 degrees C (32-120 degrees F), battery life will be maximized at an ambient temperature of 20 degrees C (68 degrees F).

Batteries may generate ignitable gases. Because of this, batteries shall be installed in a well-ventilated location, away from spark producing equipment.

Batteries shall not be installed in an atmosphere where organic solvents or adhesives may be present. The batteries shall not be cleaned with oils, thinners, or similar substances. The case and cover of the batteries are ABS plastic resin, which may suffer damage from these chemicals.

Batteries shall not be installed in a heavy vibration or shock location.

Insulated gloves shall always be worn when handling batteries.

⚠ WARNING: BATTERIES SHALL NOT BE CRUSHED, INCINERATED, OR DISMANTLED. THE ELECTROLYTE CONTAINS SULFURIC ACID, WHICH CAN CAUSE SERIOUS DAMAGE TO EYES AND SKIN. IF CONTACT DOES OCCUR, FLUSH WITH WATER AND SEEK IMMEDIATE MEDICAL ATTENTION.

Batteries of different capacities, age, or manufacturer shall not be used together.

Battery Storage

Batteries which are to be stored for an extended period of time should be given a supplement charge monthly. Batteries should never be stored in a discharged condition.

The self-discharge rate of batteries is approximately 3% per month when the storage temperature is maintained at 20 degrees C (68 degrees F). The self-discharge rate will vary depending upon temperature. Cooler temperatures cause the self-discharge rate to decrease. Warmer temperatures cause the self-discharge rate to increase.

Calculating Backup Battery Requirements

A Worksheet for assisting in calculating battery backup is available at the end of this manual.

Due to the current drain on the battery, the maximum battery size for the *SAFEPATH4 Audio Booster* is 12 Amp-Hours.

It is necessary to calculate the current draw for battery backup requirement, The current requirement depends on the system configuration and the appliances connected to the Speaker output circuits. Battery Backup current has two separate calculations that are added together. They are Standby Current and Alarm Current.

Standby Current

The standby current consumes the largest part of the storage battery capacity. The standby current of the ***SAFEPATH4 Audio Booster*** panel is 0.120 amps. If splitters are used, calculate the amount of standby current used by the splitters and add it to the Audio Booster's standby current. Multiply these values by the number of standby hours required. Normally this is 24 or 60 hours. This represents the total Standby current in amp-hours for the panel.

Alarm Current

The maximum alarm current for the ***SAFEPATH4 Audio Booster*** panel is 10.6 Amps (10.1 Amps for audio, 0.50 Amps for auxiliary power).

1. Calculate strobe circuit output current by adding the current draw of all strobes. Current draw will be in Amp-Hours.
2. Calculate speaker output circuit current by totaling all the speaker wattage settings. Multiply the sum by 0.056. The result will be the current draw in Amps.
3. Add the auxiliary current and the speaker output circuit current together. The results will be the total alarm current in Amps.

To operate for 5 minutes of alarm on battery power, multiply Step 2 by 0.232. To operate for 15 minutes of alarm on battery power, multiply Step 3 by 0.625. The result is the total alarm current in Amp-Hours.

Battery Calculations

Good engineering practices recommend the total Amp-hours required for backup should not exceed 80% of the Backup Battery capacity. The Audio Booster has been UL approved for 12AH batteries.

1. Add the total Standby Current to the total Alarm Current.
2. Multiply Step 1 by 1.25. This is the minimum Backup Battery requirement for this panel.
3. Record results on worksheet.

Section 3-9 - AC Power and Battery Installation Procedures

NOTE: Power limited and non-power limited wiring must be separated.

⚠ WARNING: TWO DIFFERENT SOURCES OF POWER MAY BE CONNECTED TO THIS UNIT. DISCONNECT BOTH SOURCES OF POWER BEFORE SERVICING. FAILURE TO DISCONNECT BOTH POWER SOURCES BEFORE SERVICING COULD RESULT IN PROPERTY DAMAGE, SERIOUS INJURY, OR DEATH TO YOU AND/OR OTHERS.

⚠ WARNING: OBSERVE CORRECT POLARITY REQUIREMENTS ON ALL CONNECTIONS. FAILURE TO DO SO MAY DAMAGE THE EQUIPMENT.

⚠ WARNING: ALWAYS APPLY AC VOLTAGE BEFORE APPLYING BATTERY BACKUP VOLTAGE. FAILURE TO DO SO MAY CAUSE DAMAGE TO THE SAFEPATH4 AUDIO BOOSTER PANEL.

AC Power Installation Procedure

1. Using Figure 3-16 on Page 33, connect the line and neutral 120VAC input wiring to the L (Line) and N (Neutral) terminals on the power supply module (SAPS).
2. Connect the ground input wiring to the grounding terminal block on the right side of the chassis.

Battery Installation Procedure

NOTE: Batteries are not supplied with this panel and must be purchased separately.

1. Connect the supplied red battery wire to the (+) terminal and the supplied black battery wire to the (-) terminal of TB4 (BATTERY) connection. (See Figure 3-17 on Page 34)

Intentionally Blank

Chapter 4 - OPERATION

Section 4-1- Introduction

This chapter describes the operating characteristics of the panel. Included is information about the following panel features:

- Supervision
- Audio Notification Appliance Output Circuit Supervision
- Amplifier Supervision
- Actions that Initiate Alarms

Section 4-2 - Supervision

A TROUBLE LED indicates that the supervisory functions have detected a malfunction in the panel. When a trouble condition is detected, the panel may not be able to receive and/or broadcast messages from the host voice evacuation panel.

If a trouble condition is detected by any of the supervisory functions, the internal sounder of the SP40/2 voice evacuation panel will operate, the audio booster Form C TROUBLE relay (normally energized) will change state, and the yellow TROUBLE LED will turn "ON". The Trouble Status Relay may be used to provide an external audible or visual alert to indicate that the audio booster is in a trouble condition. At the same time one of the yellow trouble location LEDs will identify the location of the trouble condition. If a trouble condition is indicated, follow the procedures in Chapter 7 "Troubleshooting".

⚠ WARNING: DO NOT LEAVE THE PANEL IN A TROUBLE CONDITION, AS IT MAY NOT PLAY WARNING MESSAGES FROM THE VOICE EVACUATION PANEL, WHICH COULD RESULT IN PROPERTY DAMAGE AND SERIOUS INJURY OR DEATH TO YOU AND/OR OTHERS. IF THE PANEL INDICATES A TROUBLE CONDITION: (1) PROVIDE UL REQUIRED ALTERNATIVE SIGNALING AND (2) HAVE QUALIFIED SERVICE PERSONS IMMEDIATELY REPLACE UNIT(S) THAT HAVE MALFUNCTIONED.

⚠ WARNING: MESSAGES REQUESTED BEFORE AND DURING A TROUBLE CONDITION MAY NOT BE HEARD, WHICH COULD RESULT IN PROPERTY DAMAGE AND SERIOUS INJURY OR DEATH TO YOU AND/OR OTHERS. IF MESSAGES REQUESTED BEFORE AND DURING A TROUBLE CONDITION ARE STILL NECESSARY, THEY SHOULD BE REPEATED WHEN THE PANEL IS RETURNED TO NORMAL.

Audio Notification Appliance Output Circuit Supervision (SPB-160 and SPB-80/4)

The SPB-160 has two 80 watt circuits, while the SPB-80/4 has one 80 watt circuit. The audio notification appliance output circuit uses Class B, Style Y wiring, and is supervised for open and short circuits. Output circuit supervision requires installation of UL Listed 10K Ohm, EOLR on the output circuit. A sensed open circuit trouble will illuminate D30 for AUD2 and D31 for AUD1 AUDIO OPEN LED. See Figure 7-1A/7-1B on Page 49/50 for LED location.

Visual Notification Appliance Output Circuit Supervision (SPB-80/4)

The SPB-80/4 has two 2 amp visual notifications circuits, while the SPB-160 has none. The visual notification appliance output circuit on the SPB-80/4 uses Class B, Style Y wiring, and is supervised for open and short circuits. Output circuit supervision requires installation of UL Listed 10K Ohm, EOLR on the output circuit. A sensed strobe open circuit trouble will illuminate D36 for STB1, D38 for STB2. See Figure 7-1B on Page 50.

Amplifier Supervision

A supervisory tone plays through the amplifier section during standby for supervision purpose. Any sensed trouble illuminates D36 "AMP" LED. See Figure 7-1A for the SPB-160 (Page 49) and Figure 7-1B for the SPB-80/4 (Page 50) for LED location.

Ground Fault Supervision

The panel supervises for ground fault conditions on Class B, Style Y field wiring that is not electrically isolated. The supervised wiring includes contact inputs and audio NAC circuits outputs. All other wiring is electrically isolated. Removing jumper W6 shall disable ground fault supervision. If a ground fault condition exists D60 GF LED illuminates. See Figure 7-1A for the SPB-160 (Page 49) and Figure 7-1B for the SPB-80/4 (Page 50) for LED location.

Section 4-3 - Actions That Initiate Alarms

A 25V or 70.7V input from a voice evacuation panel will initiate the voice output. On the SPB-80/4, a selection of either a 8-33VDC NAC input or a contact closure connected to the strobe input will activate the two 24VDC 2A strobe output circuits.

Chapter 5 - Operational Procedures

Section 5-1 - Operator Instructions

The SAFEPATH4 Audio Booster panels do not have specific operating instructions. When the Audio Booster is properly connected to the voice evacuation panel it will automatically function properly unless there is a trouble condition. Under normal operation the green AC LED (D59) will be lighted, and the yellow TROUBLE LED (D24) will be off.

The TROUBLE and AC LEDs identify to the operator the condition of the *SAFEPATH4* Audio Booster. The yellow TROUBLE LED will be illuminated whenever there is a trouble detected by the panel. If no troubles are detected, the green AC LED will be illuminated.

Intentionally Blank

Chapter 6 - Periodic Testing and Maintenance

Section 6-1 - Introduction

Periodic testing and maintenance of the panel and all notification equipment must be conducted frequently. Check local, state and federal codes, regulations and laws, for required tests. Qualified personnel should perform all tests and maintenance.

Section 6-2 - Periodic Testing

Test Frequency

Equipment shall be tested at least twice each year, or more often as required by local, state and federal codes, regulations and laws.

Equipment

The following equipment needs to be tested to ensure that equipment is operating properly:

- Panel
- All notification appliances

Section 6-3 - Faulty Equipment

If the notification equipment is not working properly, contact the service representative and have problems corrected immediately. If the service representative is not available, contact the manufacturer.

Malfunctioning modules in the panel shall be replaced immediately. Do not attempt to repair them.

Malfunctioning modules should be returned to the manufacturer for repair or replacement.

Section 6-4 - Qualified Personnel

Qualified personnel are those who can evaluate proper equipment functionality and ensure its proper operation and shall perform all testing procedures on the panel.

⚠ WARNING: PROVIDE ALTERNATIVE SIGNALING MEANS DURING PERIODIC TESTING TO ASSURE ADEQUATE PROTECTION OF PEOPLE AND PROPERTY. FAILURE TO PROVIDE ALTERNATIVE SIGNALING MAY CAUSE PEOPLE TO NOT BE WARNED OF AN EMERGENCY CONDITION WHICH COULD RESULT IN PROPERTY DAMAGE AND SERIOUS INJURY OR DEATH TO YOU AND/OR OTHERS.

Section 6-5 - Miscellaneous Hardware Testing

In addition to testing required by relevant fire codes, regulations, and laws, the following hardware functions shall be tested (see Table 6-1).

Table 6-1
Miscellaneous Hardware Tests

TEST/HARDWARE	TEST DESCRIPTION
Proper Operation/Status Contact	Monitor the status contact, while causing the panel to alternate between trouble and normal states to verify proper operation.

If the panel fails to perform any of the above tests correctly, Go to Chapter 7 "Troubleshooting".

Chapter 7 - Troubleshooting

Section 7-1 - Introduction

⚠ WARNING: SOME ELECTRONIC COMPONENTS STORE A HIGH VOLTAGE CHARGE, EVEN THOUGH POWER IS NOT CONNECTED, AND CAN CAUSE A DANGEROUS SHOCK IF TOUCHED. DO NOT TOUCH EXPOSED CIRCUITRY ON THE *SAFEPATH4 AUDIO BOOSTER* PANEL UNLESS THE CIRCUITRY HAS DISCHARGED FOR ONE HOUR AND A SAFE DISCHARGE PROCEDURE IS USED.

⚠ WARNING: PROVIDE UL REQUIRED ALTERNATIVE SIGNALING MEANS DURING TROUBLE CONDITIONS AND SERVICING TO ASSURE ADEQUATE PROTECTION OF PEOPLE AND PROPERTY. HAVE QUALIFIED SERVICE PERSONS IMMEDIATELY REPLACE ANY MODULES THAT HAVE MALFUNCTIONED.

⚠ CAUTION: Only qualified personnel in accordance with the procedures in this manual should conduct troubleshooting and servicing. Do not attempt to make other adjustments, modifications, or repairs. Never use water, steam, cleaning liquids or sprays on the panel.

⚠ CAUTION: User servicing of the panel is limited to field-wiring changes, PC board replacement, and following the instructions in Chapter 3 and procedures in this chapter of this manual.

AFTER ANY TROUBLESHOOTING PROCEDURE IS COMPLETED, PERFORM A COMPLETE SYSTEM CHECKOUT AS DESCRIBED IN CHAPTER 3.

Section 7-2 - Troubleshooting

The panel monitors system integrity. Items monitored for integrity are:

1. Audio appliance circuit field wiring
2. Input voltage AC (120VAC, 50-60 Hz), Backup Battery (24VDC)
3. Battery voltage level
4. Battery circuit field wiring
5. Amplifier functionality

System status is indicated to the operator via the audio supervision circuits on the voice evacuation panel, and the AC and TROUBLE LEDs, and the Trouble Form C relay contacts on the Audio Booster.

If a trouble condition is detected, the voice evacuation panel will indicate a short condition on the audio or visual output circuit.

When there are no trouble conditions detected on the Audio Booster, the AC LED will always be "ON" and the TROUBLE LED will always be "OFF". When a trouble condition is detected, the AC LED will remain "ON" and the TROUBLE LED will always be "ON".

Figure 7-1A (SPB-160) and 7-1B (SPB-80/4) shows the location of all trouble location LEDs within the Audio Booster panels. Table 7-1 on Page 51 cross-references the trouble location LEDs on the PC board to the proper troubleshooting procedure.

NOTE:When D24 TBL LED is illuminated, indicating a panel Trouble, at least 1 of the other yellow LEDs will also be illuminated indicating the trouble location.

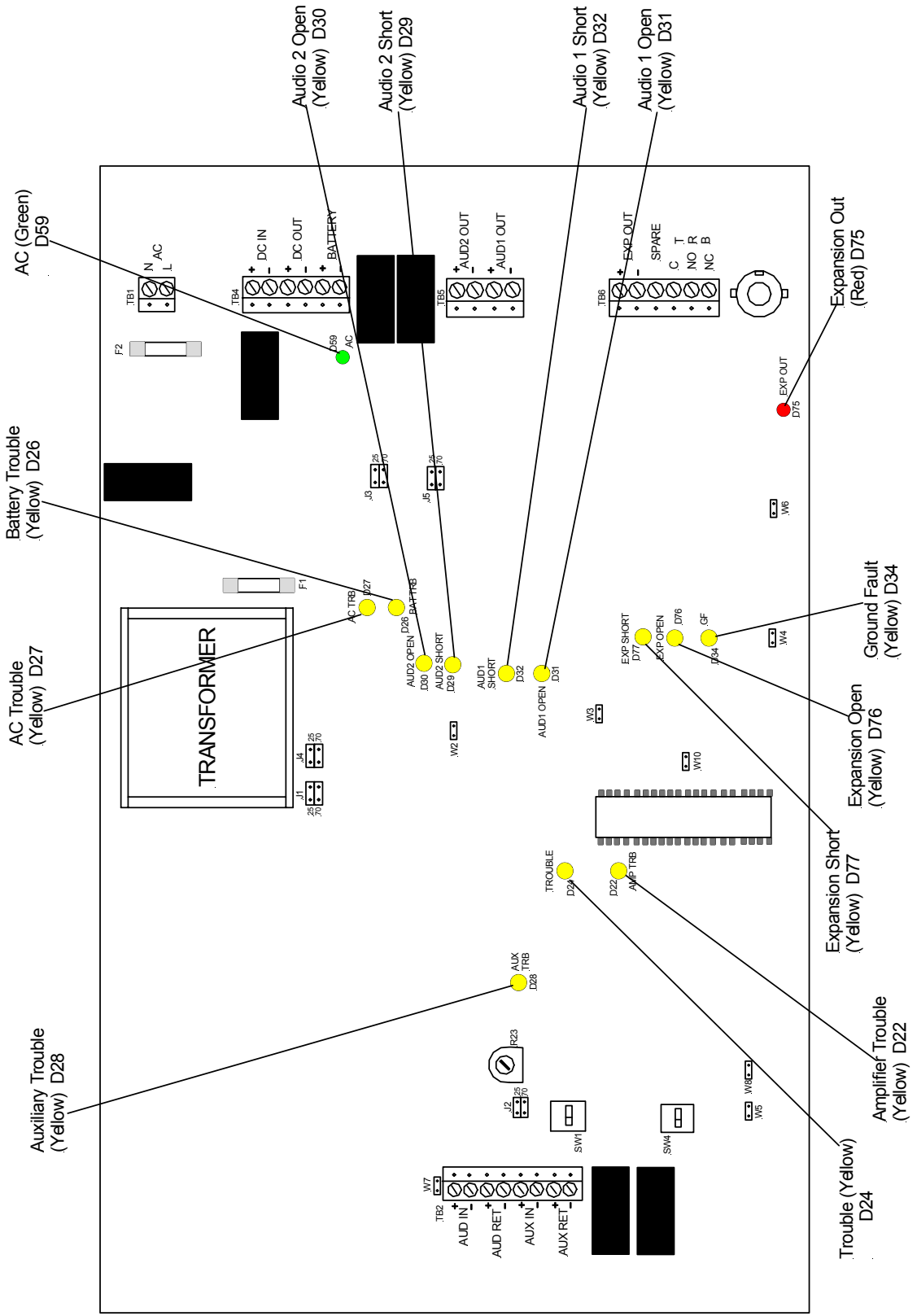

Figure 7-1A
SPB-160 LED Locations

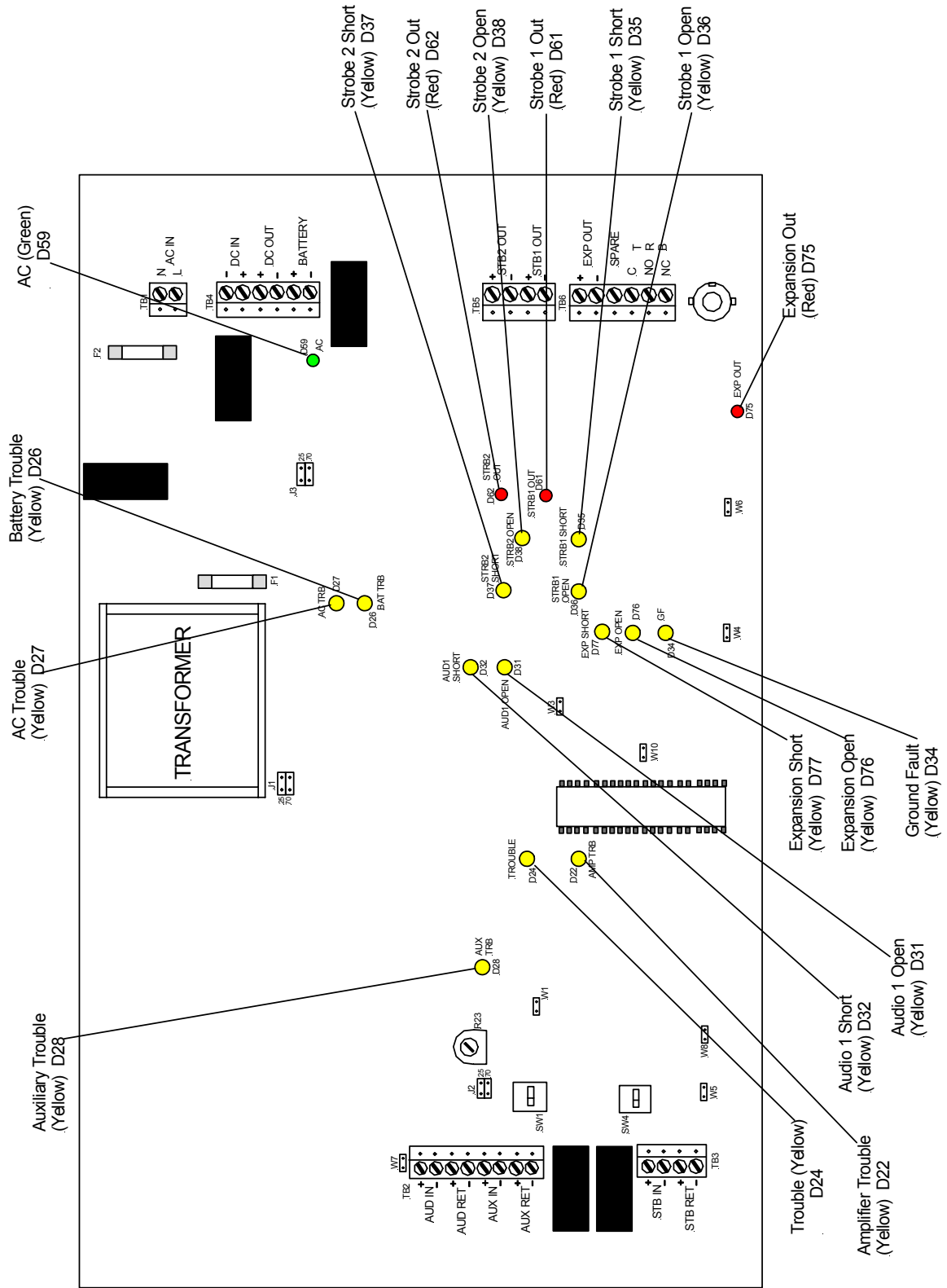

Figure 7-1B
SPB-80/4 LED Locations

**Table 7-1
Trouble LED Procedure Cross Reference**

D24 LED (Yellow)	Trouble Description	Troubleshooting Procedure
D24	Main Trouble Indicator	-----
D59 AC LED "OFF"	No DC Power to the PC Board from the Power Supply (SAPS).	Procedure A
D26 BAT TRB	Battery voltage is below 18.5 VDC or battery is missing.	Procedure B
D27 AC TRB	AC power input voltage missing from TB1.	Procedure C
D28 AUX TRB	External EOLR missing when Jumper W1 is removed.	Procedure D
D22 AMP TRB	Amplifier failure or jumpers J1, J3 or J4, J5 (SPB-160 only) are setup incorrectly.	Procedure E
D77 EXP SHORT	Expansion Circuit is Shorted	Procedure F
D76 EXP OPEN	Expansion Circuit is Open	Procedure G
D34GF	Ground Fault Trouble	Procedure H
D32 AUD1 SHORT	Audio 1 Notification Appliance Circuit is Shorted	Procedure I
D31 AUD1 OPEN	Audio 1 Notification Appliance Circuit is open	Procedure J
D29 AUD2 SHORT	Audio 2 Notification Appliance Circuit is Shorted. (SPB-160 Only)	Procedure K
D30 AUD2 OPEN	Audio 2 Notification Appliance Circuit is open. (SPB-160 Only)	Procedure L
D35 STRB1 SHORT	Strobe Notification Appliance Circuit is shorted. (SPB-80/4 Only)	Procedure M
D36 STRB1 OPEN	Strobe Notification Appliance Circuit is open. (SPB-80/4 Only)	Procedure N
D37 STRB2 SHORT	Strobe Notification Appliance Circuit is shorted. (SPB-80/4 Only)	Procedure O
D38 STRB2 OPEN	Strobe Notification Appliance Circuit is open. (SPB-80/4 Only)	Procedure P

BEFORE PERFORMING ANY OF THE FOLLOWING TROUBLESHOOTING PROCEDURES, THE PRELIMINARY TROUBLESHOOTING INFORMATION AT THE BEGINNING OF THIS "TROUBLESHOOTING" SECTION MUST BE READ, UNDERSTOOD, AND FOLLOWED.

Procedure A

If the green AC LED is "OFF", and all other LEDs are "OFF", a power loss condition has occurred. A power loss condition may be caused by:

1. Loss of AC input voltage and battery back-up voltage.
2. Faulty internal wiring between the power supply module (SAPS) and the \pm DC IN (TB4) on the PC board and batteries missing.
3. Faulty PC board.
4. Faulty Power Supply Module (SAPS)

Perform the following:

1. Check for 24 VDC at TB4 on the PC board. Check for battery installation.
2. If the 24VDC is present on TB4, replace the PC board.

NOTE: Mark all wires before removing components. When the trouble is repaired, and before testing, replace all wires to the proper locations and replace all covers.

Procedure B

If the green AC LED is "ON", yellow TROUBLE LED is "ON" and D26, BAT TRB LED is "ON", Battery Voltage is below 18.5 VDC or battery is missing. A battery trouble condition might be caused by:

1. Battery charging section of PC board is inoperable.
2. Batteries are missing.
3. Batteries are defective.
4. Battery wiring is incorrect

Perform the following:

1. Check for 24VDC at \pm BATTERY connection at TB4 on the PC board. If the voltage is below 18.5 VDC, battery-charging section of the motherboard is inoperable. Replace the Motherboard.
2. Check battery compartment for the presence of batteries. If batteries are not installed, install them.
3. Insure that batteries are properly wired.
4. If Steps 1 through 3 are satisfied replace batteries.

Procedure C

If the green AC LED is "OFF", yellow TROUBLE LED is "ON", and D27, AC TRB LED is "ON", the AC sensing circuit on connected to TB1 is not operating. An AC trouble condition might be caused by:

1. AC input missing or low.
2. No AC voltage to the AC Monitor Circuit
3. Faulty internal wiring between the rectifier module and TB1 on the motherboard.
4. A faulty PC board.

Perform the following:

1. Check AC input.
2. Check fuse F2 on PC board.
3. Check AC wiring between the power supply module and TB1 on the PC board.
4. If voltage is present replace PC board.

Procedure D

If the green AC LED is "ON", yellow TROUBLE LED is "ON", and D28, AUX TRB LED is "ON", the EOLR is missing from the AUX RET terminals when jumper W1 is removed. . An Auxiliary Trouble condition might be caused by:

1. Jumper W1 removed and no EOLR on the AUX RET terminals.
2. A faulty Motherboard. Replace.

Perform the following:

1. If the internal 10K Ohm resistor is desired, replace the jumper W1.
2. If a value other than 10K Ohms is desired for a EOLR, install the EOLR on the AUX RET terminals.
3. Replace motherboard.

Procedure E

If the green AC LED is "ON", yellow TROUBLE LED is "ON", D22 AMP TRB LED is "ON" . Amplifier section is defective. An amplifier trouble condition may be caused by:

1. Failed components.
2. 900 HZ tone missing

Perform the following:

1. Replace the Audio Booster PC board.

Procedure F

If the green AC LED is "ON", yellow TROUBLE LED is "ON", and D77 EXP SHORT LED is "ON", the supervision circuit is unable to read the EOLR: This can be caused by:

1. Expansion circuit is shorted.

Perform the following:

1. Check wiring to EXP OUT terminals and insure there is no short.

Procedure G

If the green AC LED is "ON", yellow TROUBLE LED is "ON", and D76 EXP OPEN LED is "ON", the supervision circuit is unable to read the EOLR: This can be caused by:

1. Missing or Improper EOLR
2. Open or loose wiring on the EXP OUT terminals.
3. Open EXP OUT appliance circuits.

Perform the following:

1. Check that EOLR is in place and is UL Listed 10K Ohm
2. Check wiring to EXP OUT terminals and insure there is no open circuit.
3. Troubleshoot expansion circuit for incorrect wiring.

Procedure H

If the green AC LED is "ON", yellow TROUBLE LED is "ON", and D34, GF LED is "ON", a ground fault condition exists on the output wiring. A GF trouble condition might be caused by:

1. Appliance wiring touching conduit.
2. Improper Installation of an appliance(s).

Perform the following:

1. Disconnect appliances from the strobe and speaker connection on the motherboard. Troubleshoot NAC circuits by checking for a resistance reading other than infinity between the appliance leads and the conduit.

Procedure I

If the green AC LED is "ON", yellow TROUBLE LED is "ON", and D32 AUD1 SHORT LED is "ON", the supervision circuit is unable to read the EOLR: This can be caused by:

1. Audio appliance connected is shorted.
2. Shorted connection on the AUD OUT circuits.
3. Circuit installed improperly

Perform the following:

1. Check wiring to AUD OUT terminals and insure there is no short.
2. Troubleshoot strobe circuit for incorrect wiring of an appliance or a failed appliance.

Procedure J

If the green AC LED is "ON", yellow TROUBLE LED is "ON", and D31 AUD1 OPEN LED is "ON", the supervision circuit is unable to read the EOLR: This can be caused by:

1. Missing or Improper EOLR
2. Open or loose wiring on the AUD OUT terminals.
3. Open AUD OUT appliance circuits.

Perform the following:

1. Check that EOLR is in place and is UL Listed 10K Ohm
2. Check wiring to AUD OUT terminals and insure there is no open circuit.
3. Troubleshoot audio circuit for incorrect wiring.

Procedure K (SPB-160 Only)

If the green AC LED is "ON", yellow TROUBLE LED is "ON", and D30 AUD2 SHORT LED is "ON", the supervision circuit is unable to read the EOLR: This can be caused by:

1. Audio appliance connected is shorted.
2. Shorted connection on the AUD OUT circuits.
3. Circuit installed improperly

Perform the following:

1. Check wiring to AUD OUT terminals and insure there is no short.
2. Troubleshoot strobe circuit for incorrect wiring of an appliance or a failed appliance.

Procedure L (SPB-160 Only)

If the green AC LED is "ON", yellow TROUBLE LED is "ON", and D30 AUD2 OPEN LED is "ON", the supervision circuit is unable to read the EOLR: This can be caused by:

1. Missing or Improper EOLR
2. Open or loose wiring on the AUD OUT terminals.
3. Open AUD OUT appliance circuits.

Perform the following:

1. Check that EOLR is in place and is UL Listed 10K Ohm
2. Check wiring to AUD OUT terminals and insure there is no open circuit.
3. Troubleshoot audio circuit for incorrect wiring.

Procedure M (SPB-80/4 Only)

If the green AC LED is "ON", yellow TROUBLE LED is "ON", and D35 STRB1 SHORT LED is "ON", the supervision circuit is unable to read the EOLR: This can be caused by:

1. Strobe appliance connected improperly or is shorted.
2. Shorted connection on the STB OUT circuits.
3. Circuit installed improperly

Perform the following:

1. Check wiring to STB OUT terminals and insure proper polarity.
2. Troubleshoot strobe circuit for incorrect wiring of an appliance or a failed appliance.

Procedure N (SPB-80/4 Only)

If the green AC LED is "ON", yellow TROUBLE LED is "ON", and D36 STRB1 OPEN LED is "ON", the supervision circuit is unable to read the EOLR: This can be caused by:

1. No EOLR installed.
2. Open connection on the STB OUT circuits.
3. Broken wire on the strobe circuit

Perform the following:

1. Check the EOLR and insure that it is in place and of the correct value.
1. Check Terminals to insure strobe circuit wiring is securely fastened.
2. Check system integrity.

Procedure O (SPB-80/4 Only)

If the green AC LED is "ON", yellow TROUBLE LED is "ON", and D37 STRB2 SHORT LED is "ON", the supervision circuit is unable to read the EOLR: This can be caused by:

1. Strobe appliance connected improperly or is shorted.
2. Shorted connection on the STB OUT circuits.
3. Circuit connect installed improperly

Perform the following:

1. Check wiring to STB OUT terminals and insure proper polarity.
2. Troubleshoot strobe circuit for incorrect wiring of an appliance or a failed appliance.

Procedure P (SPB-80/4 Only)

If the green AC LED is "ON", yellow TROUBLE LED is "ON", and D38 STRB2 OPEN LED is "ON", the supervision circuit is unable to read the EOLR: This can be caused by:

1. No EOLR installed.
2. Open connection on the STB OUT circuits.
3. Broken wire on the strobe circuit

Perform the following:

1. Check the EOLR and insure that it is in place and of the correct value.
2. Check Terminals to insure strobe circuit wiring is securely fastened.
3. Check system integrity.

Chapter 8 Technical Data for SPB-160 and SPB-80/4

Section 8-1- Mechanical

Table 8-1 Mechanical

Dimensions (H x W x D)	21 x 16 x 6 in.
Weight	36 lb.
Finish	Red
Enclosure Construction Type	Enclosure Door 0.05" steel Enclosure Backbox 0.62" steel
Mounting	Indoor surface mount
Wiring Entry	Top, and bottom knockouts (1") (8 total)
Door Lock	Standard Wheelock key-lock
PC Boards	1- Audio Booster PC Board 1- 24VDC Power Supply

Section 8-2 - Environmental

Table 8-2 Environmental

Operating Temperature	0 to 49 °C (32 to 120 °F)
Storage Temperature	-20 to 70 °C (-4 to 158 °F)
Humidity, Non-condensing	85±5% at 30±2 °C (86 ± 4 °F)

Section 8-3 - Electrical

Input

Table 8-3 Electrical

Input Voltage	120VAC, 3.8A, 50-60Hz
---------------	-----------------------

Battery Current Calculations

The current draw of the Audio Booster is determined by the configuration being utilized. Section 3-8 Battery Care and Battery Backup Calculation will assist you in developing the current requirements.

Activation Inputs

The panel audio output is activated by applying a 25V or 70.7V at 1.2 Watts maximum input signal to AUD IN.

The AUX IN is triggered using 8 – 33VDC at 10mA in NAC mode or with contact closure in CC mode.

Outputs

Table 8-4 Outputs

Visual Notification Appliance Output (SPB-80/4 only)	2 output circuits. 2.0 amps at 24VDC. Supervised.
Central Amplified Audio Output	(SPB-80/4) 1 output circuit. Selectable 25 or 70.7 Volt output at 80W max. Supervised. (SPB-160) 2 output circuits. Selectable 25 or 70.7 Volt output at 80W max for each. Supervised.
Trouble Contact	Form C contact normally energized. Contacts transfer during trouble: 1.0 amps at 24VDC max, resistive load (see following warning). Non-Supervised.

⚠ WARNING: DO NOT EXCEED THE RATINGS OF THE STATUS CONTACTS. EXCEEDING THIS RATING MAY CAUSE THE RELAY TO FAIL AND PREVENT A TROUBLE CONDITION FROM BEING INDICATED.

Wiring Connections

Table 8-5 Wiring Connections

Screw terminals	Accepts #12 to #18 AWG for single wire connection, or #16 to #18 AWG for double wire connection.
-----------------	--

End of Line Resistor (EOLR)

Table 8-6 EOLR

Visual Notification Appliance Outputs	UL Listed 10K Ohm, EOLR
Audio Notification Appliance Outputs	UL Listed 10K Ohm, EOLR

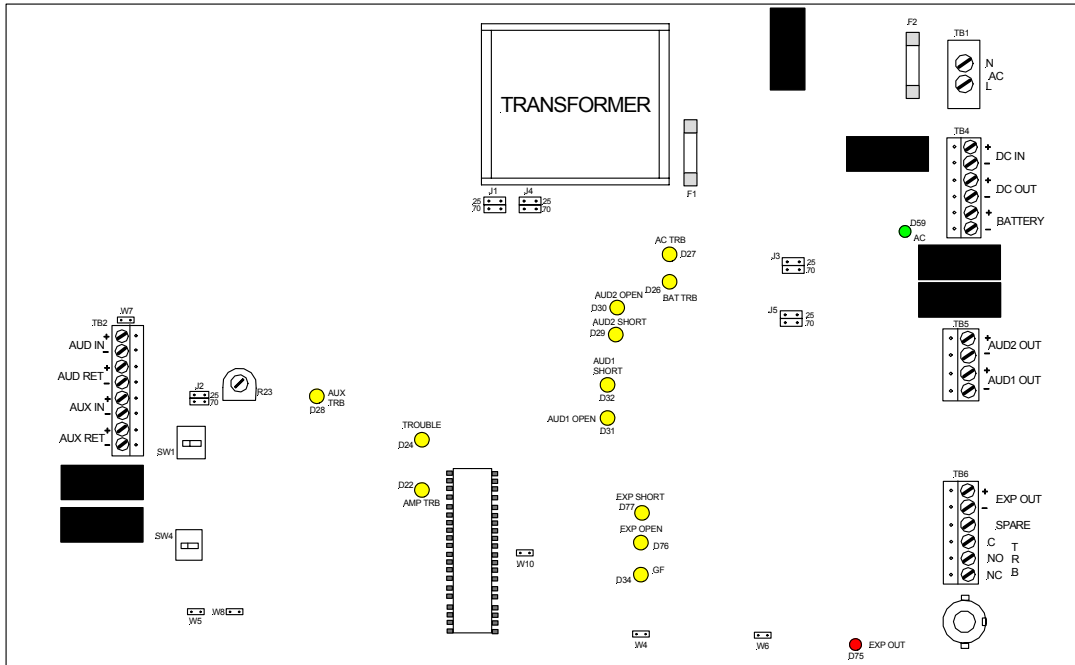

Figure 9-1B
SPB-160 PC Board

Section 9-3 - 24VDC Power Supply (SAPS)

The Power Supply Module (SAPS) converts 120VAC line voltage to 24VDC output voltage. The power supply module is capable of converting up to 500W of power and its output has over current protection.

There is one fuse on the printed circuit board, F1. Fuse F1 is the input fuse for the entire board. See Figure 9-3, below, for fuse location.

<u>Fuse</u>	<u>Rating</u>
F1	10A

Nominal Specifications:

Rated Output	500W
Input Voltage	120VAC
Supply Current (Full Load) @ 120VAC	6.4A
Operating Temperature Range	0 to 49 Degrees C (32-120 Degrees F)
Humidity Range	0 to 85%, Non-condensing

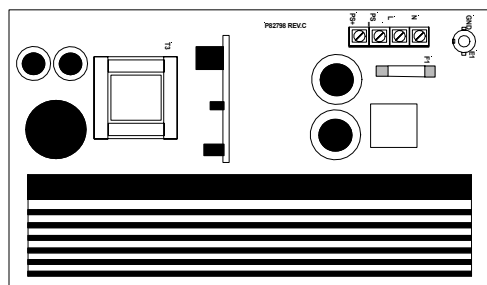

Figure 9-2
Power Supply Module (SAPS)

Chapter 10 - Warranty

Limited Warranty

Wheelock products must be used within their published specifications and must be PROPERLY specified, applied, installed, operated, maintained and operationally tested in accordance with these instructions at the time of installation and at least twice a year or more often and in accordance with local, state and federal codes, regulations and laws. Specification, application, installation, operation, maintenance and testing must be performed by qualified personnel for proper operation in accordance with all of the latest National Fire Protection Association (NFPA), Underwriters' Laboratories (UL), Underwriters' Laboratories of Canada (ULC), National Electrical Code (NEC), Occupational Safety and Health Administration (OSHA), local, state, county, province, district, federal and other applicable building and fire standards, guidelines, regulations, laws and codes including, but not limited to, all appendices and amendments and the requirements of the local authority having jurisdiction (AHJ). Wheelock products when properly specified, applied, installed, operated, maintained and operationally tested as provided above are warranted against mechanical and electrical defects for a period of three years from date of manufacture (as determined by date code). Correction of defects by repair or replacement shall be at Wheelock's sole discretion and shall constitute fulfillment of all obligations under this warranty.

THE FOREGOING LIMITED WARRANTY SHALL IMMEDIATELY TERMINATE IN THE EVENT ANY PART NOT FURNISHED BY WHEELOCK IS INSTALLED IN THE PRODUCT. THE FOREGOING LIMITED WARRANTY SPECIFICALLY EXCLUDES ANY SOFTWARE REQUIRED FOR THE OPERATION OF OR INCLUDED IN A PRODUCT. WHEELOCK MAKES NO REPRESENTATION OR WARRANTY OF ANY OTHER KIND, EXPRESS, IMPLIED OR STATUTORY WHETHER AS TO MERCHANTABILITY, FITNESS FOR A PARTICULAR PURPOSE OR ANY OTHER MATTER.

USERS ARE SOLELY RESPONSIBLE FOR DETERMINING WHETHER A PRODUCT IS SUITABLE FOR THE USER'S PURPOSES, OR WHETHER IT WILL ACHIEVE THE USER'S INTENDED RESULTS. THERE IS NO WARRANTY AGAINST DAMAGE RESULTING FROM MISAPPLICATION, IMPROPER SPECIFICATION, ABUSE, ACCIDENT OR OTHER OPERATING CONDITIONS BEYOND WHEELOCK'S CONTROL.

SOME WHEELOCK PRODUCTS CONTAIN SOFTWARE. WITH RESPECT TO THOSE PRODUCTS, WHEELOCK DOES NOT WARRANTY THAT THE OPERATION OF THE SOFTWARE WILL BE UNINTERRUPTED OR ERROR-FREE OR THAT THE SOFTWARE WILL MEET ANY OTHER STANDARD OF PERFORMANCE, OR THAT THE FUNCTIONS OR PERFORMANCE OF THE SOFTWARE WILL MEET THE USER'S REQUIREMENTS. WHEELOCK SHALL NOT BE LIABLE FOR ANY DELAYS, BREAKDOWNS, INTERRUPTIONS, LOSS, DESTRUCTION, ALTERATION, OR OTHER PROBLEMS IN THE USE OF A PRODUCT ARISING OUT OF OR CAUSED BY THE SOFTWARE.

THE LIABILITY OF WHEELOCK ARISING OUT OF THE SUPPLYING OF A PRODUCT, OR ITS USE, WHETHER ON WARRANTIES, NEGLIGENCE, OR OTHERWISE, SHALL NOT IN ANY CASE EXCEED THE COST OF CORRECTING DEFECTS AS STATED IN THE LIMITED WARRANTY AND UPON EXPIRATION OF THE WARRANTY PERIOD ALL SUCH LIABILITY SHALL TERMINATE. WHEELOCK IS NOT LIABLE FOR LABOR COSTS INCURRED IN REMOVAL, REINSTALLATION OR REPAIR OF THE PRODUCT BY ANYONE OTHER THAN WHEELOCK OR FOR DAMAGE OF ANY TYPE WHATSOEVER, INCLUDING BUT NOT LIMITED TO, LOSS OF PROFIT OR INCIDENTAL OR CONSEQUENTIAL DAMAGES. THE FOREGOING SHALL CONSTITUTE THE SOLE REMEDY OF THE PURCHASER AND THE EXCLUSIVE LIABILITY OF WHEELOCK.

IN NO CASE WILL WHEELOCK'S LIABILITY EXCEED THE PURCHASE PRICE PAID FOR A PRODUCT.

Limitation of Liability

WHEELOCK'S LIABILITY ON ANY CLAIM OF ANY KIND, INCLUDING NEGLIGENCE AND BREACH OF WARRANTY, FOR ANY LOSS OR DAMAGE RESULTING FROM, ARISING OUT OF, OR CONNECTED WITH THIS CONTRACT, OR FROM THE MANUFACTURE, SALE, DELIVERY, RESALE, REPAIR OR USE OF ANY PRODUCT COVERED BY THIS ORDER SHALL BE LIMITED TO THE PRICE APPLICABLE TO THE PRODUCT OR PART THEREOF WHICH GIVES RISE TO THE CLAIM. WHEELOCK'S LIABILITY ON ANY CLAIM OF ANY KIND SHALL CEASE IMMEDIATELY UPON THE INSTALLATION IN THE PRODUCT OF ANY PART NOT FURNISHED BY WHEELOCK. IN NO EVENT SHALL WHEELOCK BE LIABLE FOR ANY CLAIM OF ANY KIND UNLESS IT IS PROVEN THAT OUR PRODUCT WAS A DIRECT CAUSE OF SUCH CLAIM. FURTHER, IN NO EVENT, INCLUDING IN THE CASE OF A CLAIM OF NEGLIGENCE, SHALL WHEELOCK BE LIABLE FOR INCIDENTAL OR CONSEQUENTIAL DAMAGES. SOME STATES DO NOT ALLOW THE EXCLUSION OR LIMITATION OF INCIDENTAL OR CONSEQUENTIAL DAMAGES, SO THE PRECEDING LIMITATION MAY NOT APPLY TO ALL PURCHASERS.

Intentionally Blank

BATTERY BACKUP CALCULATION WORKSHEET

STANDBY CURRENT CALCULATIONS

1. Record Standby Current 0.120A

2. Multiply Step 1 by the number of hours of Standby required.
- 24 Hours - Multiply By 24 _____
- 60 Hours - Multiply By 60 _____
- TOTAL STANDBY CURRENT IN AMP HOURS.** _____

ALARM CURRENT CALCULATIONS

Good engineering practices call for each amplifier section to operate at 80% Max wattage.

3. Total the speaker wattage for Audio 1 Out and Audio 2 Out.
- Audio 1 Out total Wattage _____
- Audio 2 Out total Wattage (SPB-160) _____
- Sum the speaker Wattage.
- TOTAL SPEAKER WATTAGE** _____
4. Multiply the total wattage by 0.056. _____
5. Record the auxiliary current in amps. _____
6. Total Strobe Current (SPB-80/4 Only) _____
7. Add Steps 4, 5 and 6
- STB1 Current _____
- STB2 Current _____
8. Multiply Step 7 by the appropriate value for Alarm Time.
- SUM STB1 + STB2 _____
- 5 minutes of Alarm - multiply Step 8 by 0.232 _____
- 15 minutes of Alarm - multiply Step 8 by 0.625 _____

STEP 9 CALCULATES THE TOTAL ALARM CURRENT IN AMP HOURS

BACKUP BATTERY REQUIREMENT

1. Enter results from **Standby Current** section.

2. Enter results from **Alarm Current** section.

3. Add Steps 1 and 2 together, enter total

4. Multiply Step 3 by 1.25 for Minimum Backup Battery requirement.

Ampere Hours

NOTE: THE *Audio Booster* IS UL APPROVED FOR 12 AMP-HOUR RECHARGEABLE BATTERIES ONLY.