

Acoustic Booths



The sound proofing qualities of Guardian Telecom’s Acoustic Booths greatly enhance communication in areas with high background noise levels, while protecting the apparatus and user from the elements.

Each acoustic booth can be fitted with accessories including strobe lights, sounders, and the SR40/60 explosion proof speaker/ ringer, speaker or ringer.

Guardian
Telecom Inc.



ISO-9001:2008 Certification
Today's Quality Creates Our Future

Acoustic Booths



AB-100

18-1

- Powder coated sheet aluminum
- Perforated Galvanized Steel Liner
- Fully Acoustic insulation: Noise Attenuation -24 dB
- Interior and exterior use



AB-1000

18-1

- Glass Reinforced Plastic
- Maintenance free
- Interior, exterior and offshore use
- Noise Attenuation up to -25 dB depending on interior liner type
 - P9035 – Perforated stainless steel liner over acoustic insulation. Highly durable & vandal resistant
 - P9037 – Urethane coated interior
 - P9038 – No liner
 - P9039 – High performance polyurethane acoustic liner, resistant to mildew and rot. Fire retardant class "0" rating



AB-3000

18-1

- Polyethylene Plastic
- Maintenance free
- Interior, exterior and offshore use
- Noise Attenuation up to -25 dB depending on interior liner type
 - P9042 – High performance polyurethane acoustic liner, resistant to mildew and rot. Fire retardant class "0" rating
 - P9043 – No liner

ACOUSTIC BOOTHS

AB-100/AB-1000/AB-3000

FEATURES and BENEFITS

AB-100 – Sheet Aluminum

- Sheet Aluminum construction, powder coated
- Acoustic insulation: Noise Attenuation 24 dB
- Convenient writing shelf
- Metal mounting brackets included
- Can be used both indoors and outdoors. Not for use around salt water environments.

AB-1000 – Glass Reinforced Plastic

- Durable, lightweight reinforced laminate-fiberglass construction
- Noise Attenuation up to 25 dB depending on interior liner type
- Standard color – yellow (optional colors available, see back page¹)
- Completely maintenance free, UV and corrosion resistant, impervious to chemical attack
- Convenient writing shelf
- Encapsulated strong points to securely mount stations and accessories
- Can be used both indoors, outdoors and offshore

AB-3000 – Polyethylene Plastic

- Durable, lightweight, chemical resistant body
- Acoustic insulation: Noise Attenuation up to 25 dB depending on interior liner type
- Excellent low temperatures impact properties
- Polyethylene material ANSI/UL94 flammability approved
- High performance polyurethane acoustic liner, resistant to mildew and rot. Fire retardant class "0" rating
- Standard color – yellow (optional colors available, see back page¹)
- Completely maintenance free, UV and corrosion resistant, impervious to chemical attack
- Convenient writing shelf
- Drainage holes to prevent water accumulation
- Can be used both indoors, outdoors and offshore

APPLICATIONS

- Refineries
- Factories
- Nuclear facilities
- Steel mills
- Aerospace
- Chemical plants
- Mines
- Drilling rigs
- Bulk loading stations
- Offshore platforms (AB-1000 and AB-3000 only)
- Any high noise industrial location and more . . .

ACCESSORIES and OPTIONS

Each Acoustic Booth can be fitted with a Guardian telephone suited for specific needs and requirements, and equipped with:

- An assortment of rugged industrial speakers including the SR40 explosion proof speaker/ringer, speaker or ringer (up to 110 dB)
- Strobe light
- Combination strobe light & sounder

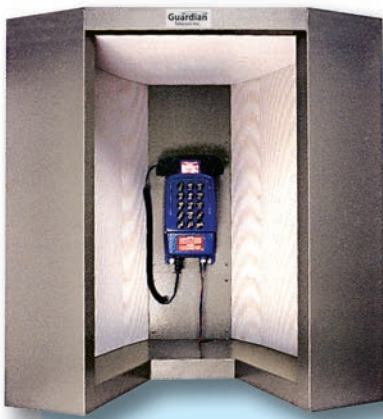

AB-100 with perforated galvanized steel liner¹



AB-1000 with high performance polyurethane acoustic liner¹



AB-3000 with high performance polyurethane acoustic liner¹

The sound proofing qualities of Guardian Telecom's acoustic booths greatly enhance communication in areas with high background noise levels, while protecting the apparatus and user from the elements.



SR40/SR60 Loudspeaker/Ringer

Omnidirectional Horn & Strobe

Guardian
Telecom Inc.



ISO-9001:2009 Certification
Today's Quality Creates Our Future

OVERALL DIMENSIONS AB-100 Acoustic Booth (Sheet Aluminum)

Body Construction 14 Ga Aluminum Outer Shell
 Body Dimensions (H x W x D) 36" x 36" x 31" (914 x 914 x 788 mm)
 Net Weight 100 lbs (45.4 kg)
 Shipping Weight w/o pallet 105 lbs (47.7 kg) w/pallet¹ 135 lbs (61.3 kg)
 Shipping Dimensions (L x W x D) w/o pallet¹ 40.0" x 35.0" x 37.0" (102 x 89 x 94 cm)
 Finish Hammertone Grey – Powder Coated
 Liner White – Zinc Dichromate Plated & Powder Coated
 Acoustic Insulation 2" (50.8mm) Semi-rigid
 Standard Mounting Vertical Wall
 Optional Mounting Pole or Stanchion Mount Bracket

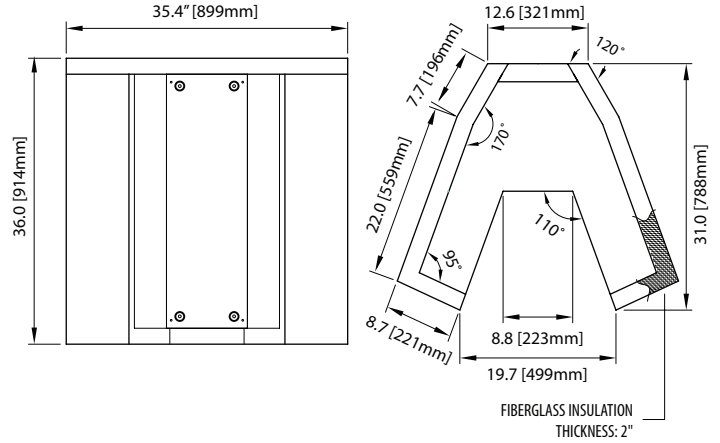

ORDERING INFORMATION

Warranty: One year parts and labor

Order No.	Description			Noise Attenuation (Up to)
	Shell	Perforated Galvanized Steel Liner	Fully Insulated	
P9010	●	●	●	24 dB

OVERALL DIMENSIONS AB-1000 Acoustic Booth (Glass Reinforced Plastic)

Body Construction Polyester/Fiberglass Reinforced Laminate Construction
 Net Weight Shell (P9038) 33.5 lbs (15.2 kg), Urethane (P9037) 40.0 lbs (18.2 kg)
 Polyurethane (P9039) 45.0 lbs (20.4 kg), Fully Lined (P9035) 45.0 lbs (20.4 kg)
 Shipping Weight Shell (P9038) 36.5 lbs (16.6 kg), Urethane (P9037) 43.0 lbs (19.5 kg)
 Polyurethane (P9039) 48.0 lbs (21.8 kg), Fully Lined (P9035) 48.0 lbs (21.8 kg)
 Shipping Dimensions (L x W x D) 28.0" x 25.0" x 28.0" (71 x 64 x 71 cm)
 Finish Polyester Gelcoat Moulded into Finish
 Standard Mounting Vertical Wall
 Standard Color Yellow – Custom Colors Available²

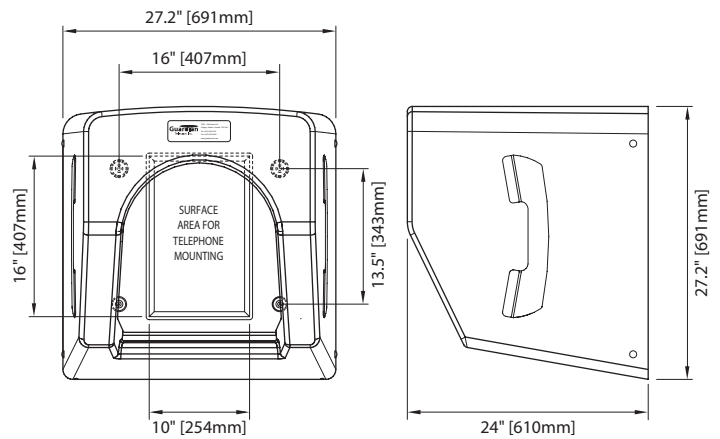

ORDERING INFORMATION

Warranty: One year parts and labor

Order No.	Description					Noise Attenuation (Up to)
	Shell	Urethane Coated Interior	Stainless Steel Liner	Acoustic Insulation	Polyurethane Acoustic Insulation	
P9035	●		●	●		23 dB
P9037	●	●				11 dB
P9038	●					8 dB
P9039	●				●	25 dB

OVERALL DIMENSIONS AB-3000 Acoustic Booth (Polyethylene Plastic)

Body Construction Polyethylene Plastic
 Body Dimensions (H x W x D) 27" x 24" x 20" (686 x 610 x 508 mm)
 Net Weight Polyurethane (P9042) 29 lbs (13.16 kg), Shell (P9043) 19.0 lbs (8.6 kg)
 Shipping Weight Polyurethane (P9042) 34 lbs (15.5 kg), Shell (P9043) 24.0 lbs (10.9 kg)
 Shipping Dimensions (L x W x D) 28.0" x 25.0" x 28.0" (71 x 64 x 71 cm)
 Acoustic Insulation Polyurethane
 Standard Mounting Vertical Wall

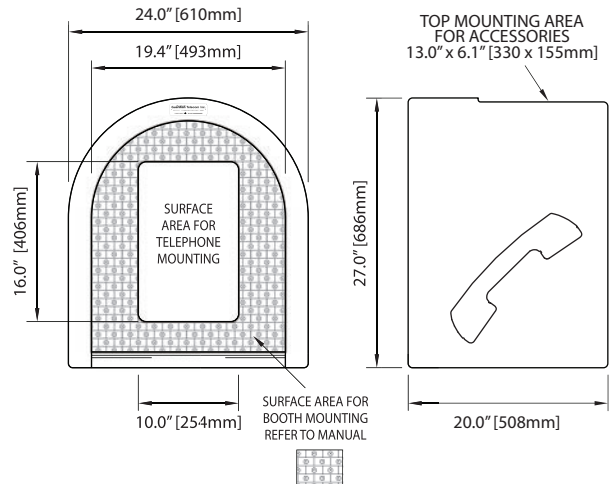

ORDERING INFORMATION

Warranty: One year parts and labor

Order No.	Description		Noise Attenuation (Up to)
	Shell	Polyurethane Acoustic Liner	
P9042	●	●	25 dB
P9043	●		8 dB

Distributed by:

¹ Telephones & accessories are sold separately. Shown for representation only.
² Minimum quantities or premiums may apply.
 For details on custom options contact a Guardian Telecom sales representative.

Sections

Guardian Telecom's Product and Services Guide Catalogue is a combination of individual Category Section Publications

Guardian 1

► About Guardian Telecom

- Building on a legacy of design and service
- Communications: Easy, Reliable and Safe
- More Choices, Selections and Services
- Standard Features
- Options & Accessories

- Product and Project Consultation
- Commissioning Services
- Sound Studies
- Training
- Maintenance, Cleaning, Trouble Shooting & Refurbishment

- Custom Design
- Page/Talk, Telephone, PA/GA and Talk/Back Systems
- Standards and Classifications
- Knowledge Base
- Glossary

Products

Analog Telephones

<p><i>Explosion Proof</i></p>  <p style="text-align: right; background-color: #C00000; color: white; padding: 2px;">2</p>	<p><i>ATEX-IEC</i></p>  <p style="text-align: right; background-color: #C00000; color: white; padding: 2px;">3</p>	<p><i>Hazardous Area</i></p>  <p style="text-align: right; background-color: #800080; color: white; padding: 2px;">4</p>	<p><i>Outdoor/Indoor Industrial</i></p>  <p style="text-align: right; background-color: #FF8C00; color: white; padding: 2px;">5</p>
<p><i>Indoor Industrial</i></p>  <p style="text-align: right; background-color: #0070C0; color: white; padding: 2px;">6</p>	<p><i>Emergency</i></p>  <p style="text-align: right; background-color: #FFD700; color: black; padding: 2px;">7</p>	<p><i>Correctional</i></p>  <p style="text-align: right; background-color: #808080; color: white; padding: 2px;">8</p>	<p><i>Institutional</i></p>  <p style="text-align: right; background-color: #008000; color: white; padding: 2px;">9</p>

VoIP Telephones

<p><i>Outdoor/Indoor Industrial VoIP</i></p>  <p style="text-align: right; background-color: #C00000; color: white; padding: 2px;">10</p>	<p><i>Indoor Industrial VoIP</i></p>  <p style="text-align: right; background-color: #C00000; color: white; padding: 2px;">10</p>	<p><i>Emergency VoIP</i></p>  <p style="text-align: right; background-color: #C00000; color: white; padding: 2px;">10</p>
--	--	--

Page/Talk

<p><i>Explosion Proof</i></p>  <p style="text-align: right; background-color: #FF8C00; color: white; padding: 2px;">11</p>	<p><i>Stations</i></p>  <p style="text-align: right; background-color: #800080; color: white; padding: 2px;">12</p>	<p><i>System Cable</i></p>  <p style="text-align: right; background-color: #808000; color: white; padding: 2px;">13</p>	<p><i>System Components</i></p>  <p style="text-align: right; background-color: #FF8C00; color: white; padding: 2px;">14</p>
---	--	---	---

Third-Party Page Station Replacement



15

Talk/Back

<p><i>Explosion Proof</i></p>  <p style="text-align: right; background-color: #FF8C00; color: white; padding: 2px;">16</p>	<p><i>Amplifiers</i></p>  <p style="text-align: right; background-color: #FF8C00; color: white; padding: 2px;">16</p>
--	--

PA/GA



17

Acoustic Booths



18

Loudspeakers/Ringers



<p><i>Explosion Proof</i></p>  <p style="text-align: right; background-color: #C00000; color: white; padding: 2px;">19</p>	<p><i>Hazardous Area</i></p>  <p style="text-align: right; background-color: #FFD700; color: black; padding: 2px;">20</p>	<p><i>ATEX-IEC</i></p>  <p style="text-align: right; background-color: #808000; color: white; padding: 2px;">21</p>	<p><i>General Area</i></p>  <p style="text-align: right; background-color: #0070C0; color: white; padding: 2px;">22</p>
---	--	---	--

Guardian represents DNH, Federal Signal, MEDC and TOA, and has access to an extensive range of world class leading manufacturers.

Contact a Channel Partner or visit Guardian's website www.guardiantelecom.com for additional information on Hazardous Area, ATEX-IEC, General Area and Explosion Proof Loudspeakers & Ringers.

Accessories & Enclosures

<p><i>Telephone</i></p>  <p style="text-align: right; background-color: #808000; color: white; padding: 2px;">23</p>	<p><i>Page/Talk</i></p>  <p style="text-align: right; background-color: #0070C0; color: white; padding: 2px;">24</p>
--	---

Product Index 25



7552 - 10th Street N.E., Calgary, Alberta, Canada T2E 8W1
Telephone: 403 258-3100 Facsimile: 403 253-4967
1-800-363-8010 (North America)
info@guardiantelecom.com

Canada USA Middle East

All content including the "Guardian Telecom" logo, images, graphics and descriptions are not to be used without the expressed written authorization of Guardian Telecom Inc., Calgary, Alberta, Canada. All other names and logos are the trademarks or registered trademarks of their respective companies.

Guardian pursues a policy of continuous improvement, therefore product, content and specifications are subject to change without notice. Design, specifications and release dates are subject to change without notice.